



Product Specification

AU OPTRONICS CORPORATION B156XW01

Contents

1. Handling Precautions	4
2. General Description	5
2.1 General Specification.....	5
2.2 Optical Characteristics.....	6
3. Functional Block Diagram	11
4. Absolute Maximum Ratings	12
4.1 Absolute Ratings of TFT LCD Module	12
4.2 Absolute Ratings of Backlight Unit	12
4.3 Absolute Ratings of Environment	12
5. Electrical characteristics	13
5.1 TFT LCD Module	13
5.2 Backlight Unit.....	15
6. Signal Characteristic	17
6.1 Pixel Format Image	17
6.2 The input data format.....	18
6.3 Signal Description/Pin Assignment.....	19
6.4 Interface Timing	21
7. Connector Description	24
7.1 TFT LCD Module	24
7.2 Backlight Unit.....	24
7.3 Signal for Lamp connector	24
8. Dynamic Test	25
8.1 Vibration Test	25
8.2 Shock Test Spec:	25
9. Reliability	26
10. Mechanical Characteristics	27
10.1 LCM Outline Dimension	27
10.2 Screw Hole Depth and Center Position	29
11. Shipping and Package	30
11.1 Shipping Label Format.....	30
11.2 Carton package	31
11.3 Shipping package of palletizing sequence	31
12. Appendix: EDID description	32



Product Specification

AU OPTRONICS CORPORATION B156XW01

Record of Revision

Version and Date	Page	Old description	New Description	Remark
0.1 2007/11/28	All	Initial Edition		



Product Specification

AU OPTRONICS CORPORATION B156XW01

1. Handling Precautions

- 1) Since front polarizer is easily damaged, pay attention not to scratch it.
- 2) Be sure to turn off power supply when inserting or disconnecting from input connector.
- 3) Wipe off water drop immediately. Long contact with water may cause discoloration or spots.
- 4) When the panel surface is soiled, wipe it with absorbent cotton or other soft cloth.
- 5) Since the panel is made of glass, it may break or crack if dropped or bumped on hard surface.
- 6) Since CMOS LSI is used in this module, take care of static electricity and insure human earth when handling.
- 7) Do not open nor modify the Module Assembly.
- 8) Do not press the reflector sheet at the back of the module to any directions.
- 9) In case if a Module has to be put back into the packing container slot after once it was taken out from the container, do not press the center of the CCFL Reflector edge. Instead, press at the far ends of the CCFL Reflector edge softly. Otherwise the TFT Module may be damaged.
- 10) At the insertion or removal of the Signal Interface Connector, be sure not to rotate nor tilt the Interface Connector of the TFT Module.
- 11) After installation of the TFT Module into an enclosure (Notebook PC Bezel, for example), do not twist nor bend the TFT Module even momentary. At designing the enclosure, it should be taken into consideration that no bending/twisting forces are applied to the TFT Module from outside. Otherwise the TFT Module may be damaged.
- 12) Cold cathode fluorescent lamp (CCFL) in LCD contains a small amount of mercury. Please follow local ordinances or regulations for disposal.
- 13) Small amount of materials having no flammability grade is used in the LCD module. The LCD module should be supplied by power complied with requirements of Limited Power Source (IEC60950 or UL1950), or be applied exemption.
- 14) The LCD module is designed so that the CCFL in it is supplied by Limited Current Circuit (IEC60950 or UL1950). Do not connect the CCFL in Hazardous Voltage Circuit.



Product Specification

AU OPTRONICS CORPORATION B156XW01

2. General Description

B156XW01 V0 is a Color Active Matrix Liquid Crystal Display composed of a TFT LCD panel, a driver circuit, and backlight system. The screen format is intended to support the WXGA (1366(H) x 768(V)) screen and 262k colors (RGB 6-bits data driver) without backlight inverter. All input signals are LVDS interface compatible.

B156XW01 V0 is designed for a display unit of notebook style personal computer and industrial machine.

2.1 General Specification

The following items are characteristics summary on the table at 25 °C condition:

Items	Unit	Specifications																
Screen Diagonal	[mm]	394.9(15.6"W)																
Active Area	[mm]	344.232(H) X 193.536(V)																
Pixels H x V		1366x3(RGB) x 768																
Pixel Pitch	[mm]	0.255X0.255																
Pixel Format		R.G.B. Vertical Stripe																
Display Mode		Normally White																
White Luminance (ICCFL=6.5mA) Note: ICCFL is lamp current	[cd/m ²]	220 typ. (5 points average) TBD min. (5 points average) (Note1)																
Luminance Uniformity		1.25 max. (5 points)																
Contrast Ratio		400 min																
Response Time	[ms]	8 typ / 15 Max																
Nominal Input Voltage VDD	[Volt]	+3.3 typ.																
Power Consumption	[Watt]	7 max. (Include Logic and Backlight)																
Weight	[Grams]	550 max.																
Physical Size	[mm]	<table border="1"> <thead> <tr> <th></th> <th>L</th> <th>W</th> <th>T</th> </tr> </thead> <tbody> <tr> <td>Max</td> <td>359.8</td> <td>210.0</td> <td>6.4</td> </tr> <tr> <td>Typical</td> <td>359.3</td> <td>209.5</td> <td></td> </tr> <tr> <td>Min</td> <td></td> <td></td> <td></td> </tr> </tbody> </table>		L	W	T	Max	359.8	210.0	6.4	Typical	359.3	209.5		Min			
			L	W	T													
		Max	359.8	210.0	6.4													
		Typical	359.3	209.5														
Min																		
Electrical Interface		1 channel LVDS																
Surface Treatment		Glare, Hardness																
Support Color		262K colors (RGB 6-bit)																
Temperature Range Operating	[°C]	0 to +50																
Storage (Non-Operating)	[°C]	-20 to +60																
RoHS Compliance		RoHS Compliance																



Product Specification

AU OPTRONICS CORPORATION B156XW01

2.2 Optical Characteristics

The optical characteristics are measured under stable conditions at 25°C (Room Temperature) :

Item	Unit	Conditions	Min.	Typ.	Max.	Note
White Luminance ICCFL=6.5mA	[cd/m ²]	5 points average	TBD	220	-	1, 4, 5.
Viewing Angle	[degree]	Horizontal (Right)	40	45	-	8
	[degree]	CR = 10 (Left)	40	45	-	
	[degree]	Vertical (Upper)	10	15	-	
	[degree]	CR = 10 (Lower)	20	35	-	
Luminance Uniformity		5 Points	-	-	1.25	1
Luminance Uniformity		13 Points	-	-		2
CR: Contrast Ratio			400	500	-	6
Cross talk	%				TBD	7
Response Time	[msec]	Rising	-	-	-	8
	[msec]	Falling	-	-	-	
	[msec]	Rising + Falling	-	8	15	
Chromaticity of color Coordinates (CIE 1931)		Red x	TBD	TBD	TBD	2,8
		Red y	TBD	TBD	TBD	
		Green x	TBD	TBD	TBD	
		Green y	TBD	TBD	TBD	
		Blue x	TBD	TBD	TBD	
		Blue y	TBD	TBD	TBD	
		White x	0.283	0.313	0.343	
	White y	0.299	0.329	0.359		
NTSC	%	CIE 1931	-	60	-	



Product Specification

AU OPTRONICS CORPORATION B156XW01

Note 1: 5 points position (Ref: Active area)

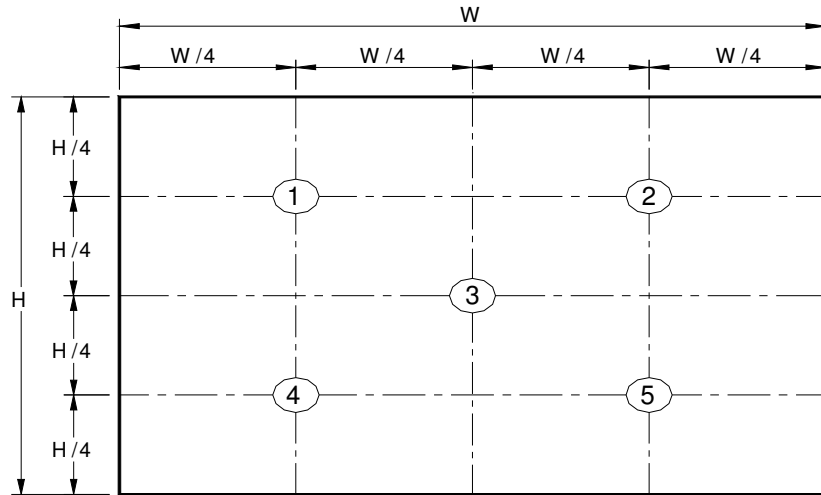

Note 2: 13 points position (Ref: Active area)

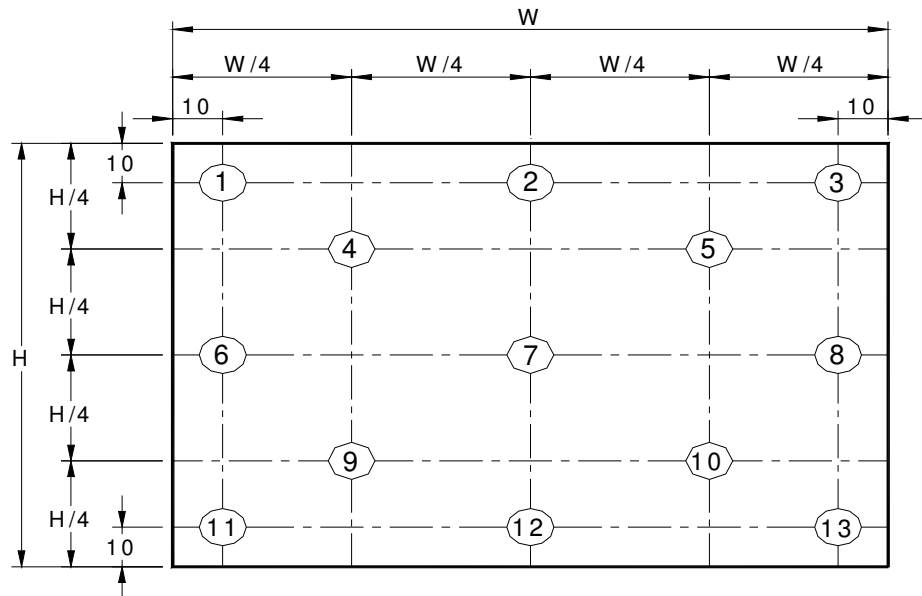

Note 3: The luminance uniformity of 5 or 13 points is defined by dividing the maximum luminance values by the minimum test point luminance

$$\delta_{w5} = \frac{\text{Maximum Brightness of five points}}{\text{Minimum Brightness of five points}}$$

$$\delta_{w13} = \frac{\text{Maximum Brightness of thirteen points}}{\text{Minimum Brightness of thirteen points}}$$



Product Specification

AU OPTRONICS CORPORATION B156XW01

Note 4: Measurement method

The LCD module should be stabilized at given temperature for 30 minutes to avoid abrupt temperature change during measuring. In order to stabilize the luminance, the measurement should be executed after lighting Backlight for 30 minutes in a stable, windless and dark room.

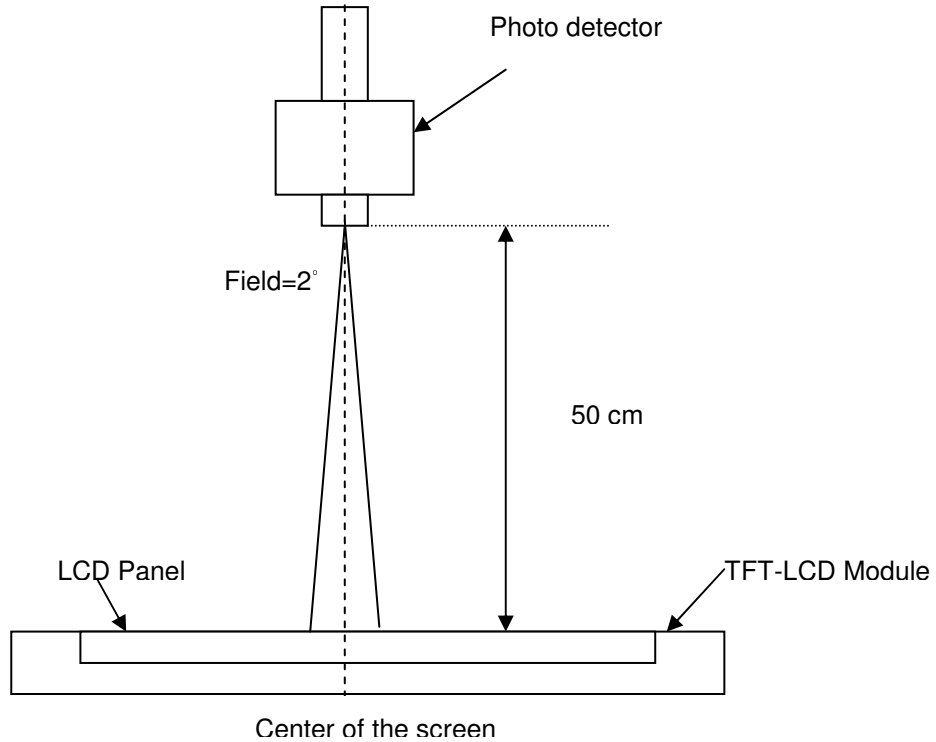

Note 5 : Definition of Average Luminance of White (Y_L):

Measure the luminance of gray level 63 at 5 points · $Y_L = [L (1)+ L (2)+ L (3)+ L (4)+ L (5)] / 5$

$L (x)$ is corresponding to the luminance of the point X at Figure in Note (1).

Note 6 : Definition of contrast ratio:

Contrast ratio is calculated with the following formula.

$$\text{Contrast ratio (CR)} = \frac{\text{Brightness on the "White" state}}{\text{Brightness on the "Black" state}}$$

Note 7 : Definition of Cross Talk (CT)

$$CT = | Y_B - Y_A | / Y_A \times 100 (\%)$$



Product Specification

AU OPTRONICS CORPORATION B156XW01

Where

Y_A = Luminance of measured location without gray level 0 pattern (cd/m²)

Y_B = Luminance of measured location with gray level 0 pattern (cd/m²)

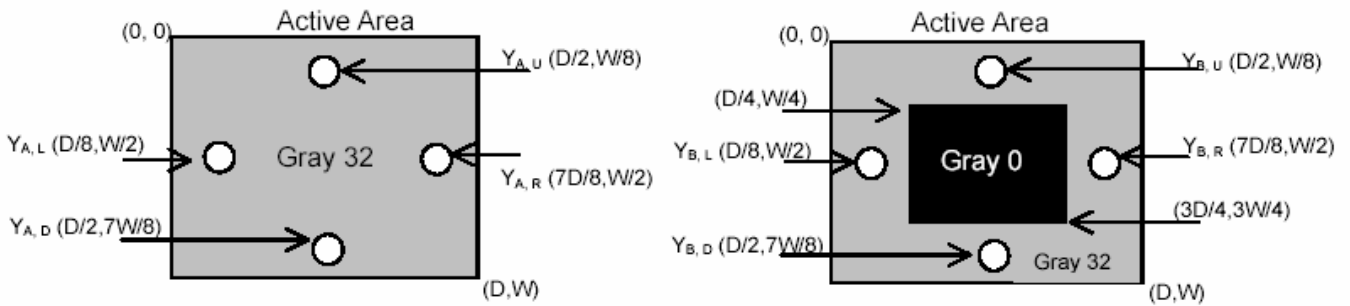

Note 8: Definition of response time:

The output signals of BM-7 or equivalent are measured when the input signals are changed from "Black" to "White" (falling time) and from "White" to "Black" (rising time), respectively. The response time interval between the 10% and 90% of amplitudes. Refer to figure as below.

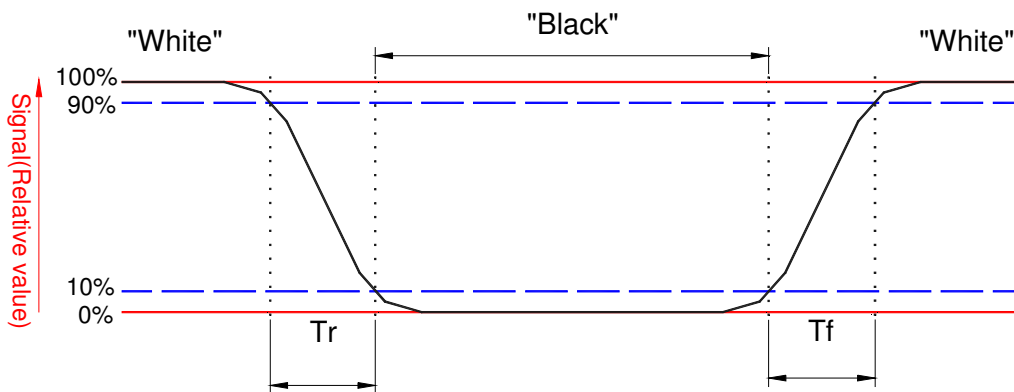



Product Specification

AU OPTRONICS CORPORATION B156XW01

Note 8. Definition of viewing angle

Viewing angle is the measurement of contrast ratio ≥ 10 , at the screen center, over a 180° horizontal and 180° vertical range (off-normal viewing angles). The 180° viewing angle range is broken down as follows; 90° (θ) horizontal left and right and 90° (ϕ) vertical, high (up) and low (down). The measurement direction is typically perpendicular to the display surface with the screen rotated about its center to develop the desired measurement viewing angle.

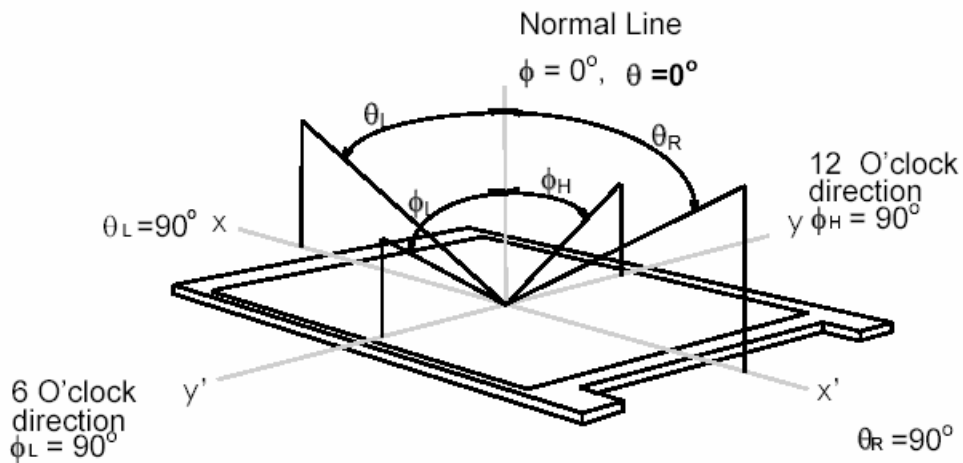



Product Specification

AU OPTRONICS CORPORATION B156XW01

3. Functional Block Diagram

The following diagram shows the functional block of the 15.6 inches wide Color TFT/LCD Module:

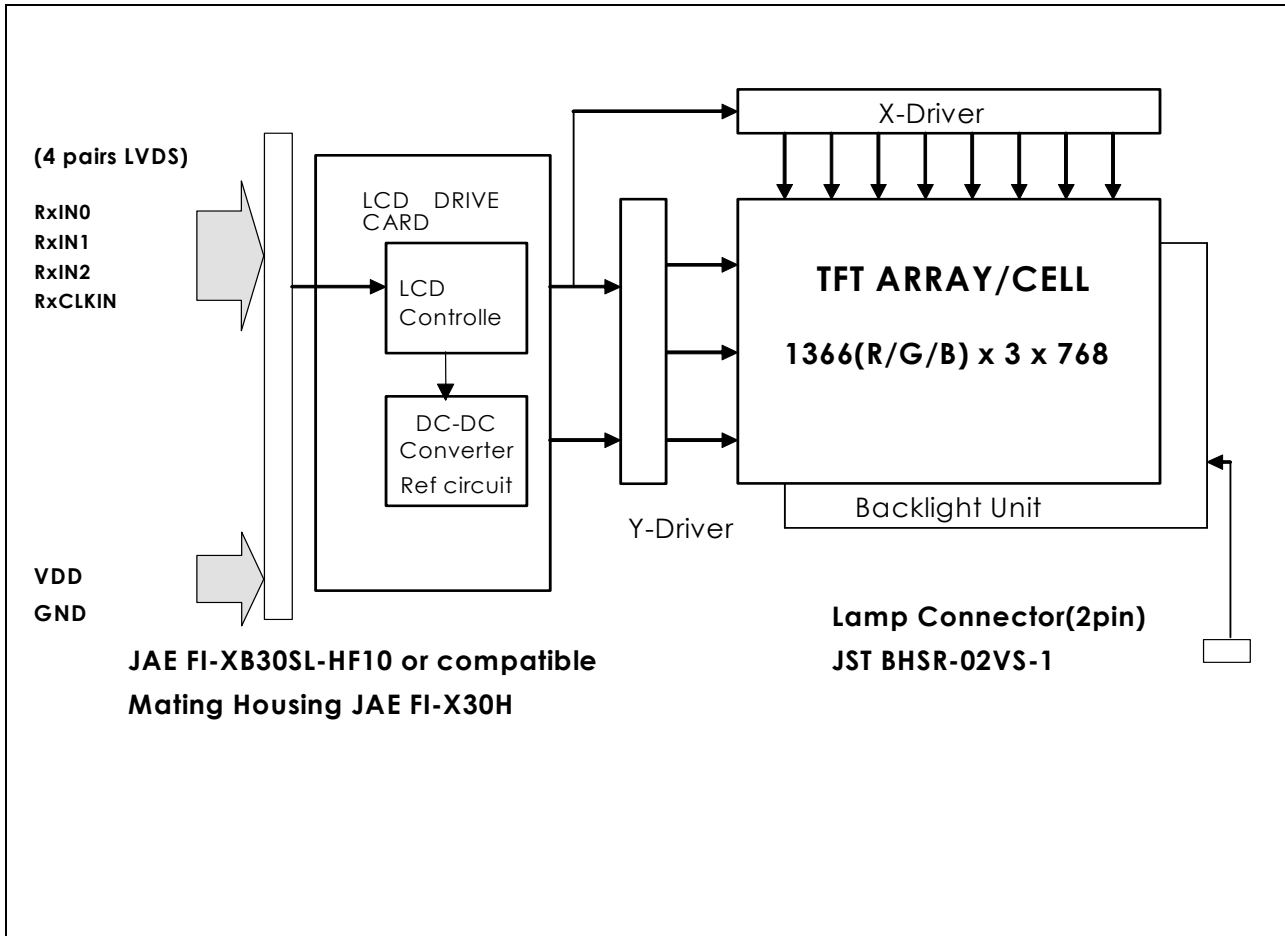



Product Specification

AU OPTRONICS CORPORATION B156XW01

4. Absolute Maximum Ratings

An absolute maximum rating of the module is as following:

4.1 Absolute Ratings of TFT LCD Module

Item	Symbol	Min	Max	Unit	Conditions
Logic/LCD Drive	Vin	-0.3	+4.0	[Volt]	Note 1,2

4.2 Absolute Ratings of Backlight Unit

Item	Symbol	Min	Max	Unit	Conditions
CCFL Current	ICCFL	-	6.0	[mA] rms	Note 1,2

4.3 Absolute Ratings of Environment

Item	Symbol	Min	Max	Unit	Conditions
Operating	TOP	0	+50	[°C]	Note 3
Operation Humidity	HOP	5	95	[%RH]	Note 3
Storage Temperature	TST	-20	+60	[°C]	Note 3
Storage Humidity	HST	5	95	[%RH]	Note 3

Note 1: At Ta (25°C)

Note 2: Permanent damage to the device may occur if exceed maximum values

Note 3: For quality performance, please refer to AUO IIS (Incoming Inspection Standard).

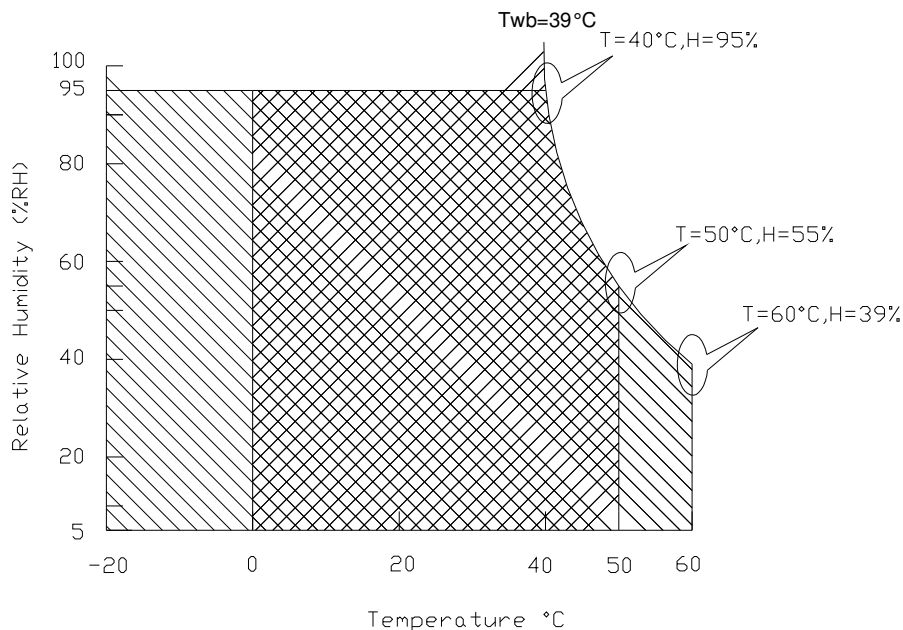

Operating Range

Storage Range +



Product Specification

AU OPTRONICS CORPORATION B156XW01

5. Electrical characteristics

5.1 TFT LCD Module

5.1.1 Power Specification

Input power specifications are as follows;

Symble	Parameter	Min	Typ	Max	Units	Note
VDD	Logic/LCD Drive Voltage	3.0	3.3	3.6	[Volt]	
PDD	VDD Power			TBD	[Watt]	Note 1/2
IDD	IDD Current		TBD	TBD	[mA]	Note 1/2
IRush	Inrush Current			TBD	[mA]	Note 3
VDDrp	Allowable Logic/LCD Drive Ripple Voltage			TBD	[mV] p-p	

Note 1 : Maximum Measurement Condition : Black Pattern

Note 2 : Typical Measurement Condition: Mosaic Pattern

Note 3 : Measure Condition

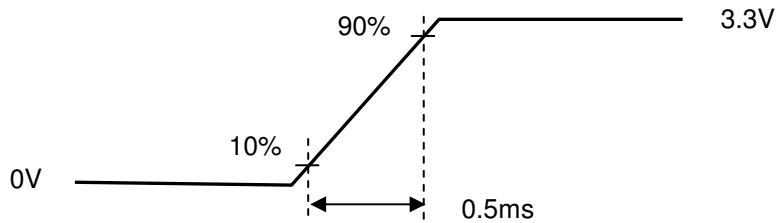
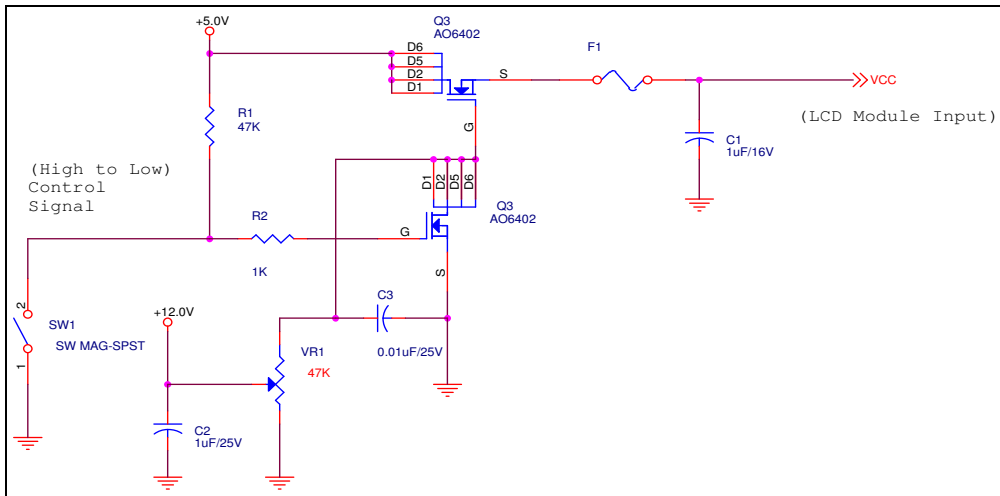



Product Specification

AU OPTRONICS CORPORATION B156XW01

5.1.2 Signal Electrical Characteristics

Input signals shall be low or High-impedance state when VDD is off.

It is recommended to refer the specifications of THC63LVDF84A (Thine Electronics Inc.) in detail.

Signal electrical characteristics are as follows;

Parameter	Condition	Min	Max	Unit
Vth	Differential Input High Threshold (Vcm=+1.2V)	-	100	[mV]
Vtl	Differential Input Low Threshold (Vcm=+1.2V)	-100	-	[mV]
Vcm	Differential Input Common Mode Voltage	1.125	1.375	[V]

Note: LVDS Signal Waveform

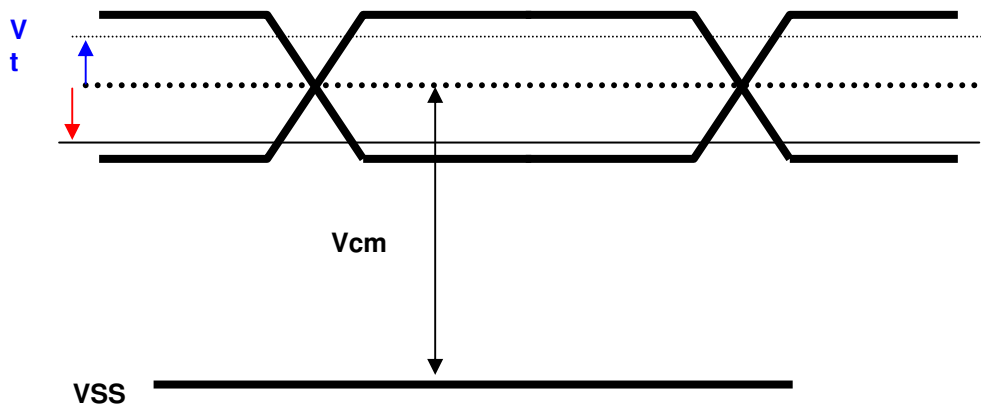



Product Specification

AU OPTRONICS CORPORATION B156XW01

5.2 Backlight Unit

CCFL Parameter guideline for CCFL Inverter selection (Ref. Remark 1)

Parameter	Min	Typ	Max	Units	Condition
CCFL current(I _{CCFL})	4.0	6.5	7.0	[mA] rms	(T _a =25°C) Note 1
CCFL Frequency(F _{CCFL})	TBD	TBD	TBD	[KHz]	(T _a =25°C) Note 2,3
CCFL startup Voltage(V _s)	--	TBD	TBD	[Volt] rms	(T _a = 0°C) Note 4
CCFL startup Voltage(V _s)	--	TBD	TBD	[Volt] rms	(T _a = 25°C) Note 4
CCFL Voltage (Reference) (V _{CCFL})	TBD	TBD	TBD	[Volt] rms	(T _a =25°C) Note 5
CCFL Power consumption (P _{CCFL})	TBD	TBD	TBD	[Watt]	(T _a =25°C) Note 5
CCFL Life-Time	12,000	-	-	Hour	(T _a =25°C) Note 7

To optimun TFT LCD performance, the LAMP inverter PWM Frequesncy define as: 210 +/-5 Hz

Remark 1: Typ are AUO recommended Design Points.

- 1-1 All of characteristics listed are measured under the condition using the AUO Test inverter.
- 1-2 In case of using an inverter other than listed, it is recommended to check the inverter carefully. Sometimes, interfering noise stripes appear on the screen, and substandard luminance or flicker at low power may happen.
- 1-3 In designing an inverter, it is suggested to check safety circuit very carefully. Impedance of CCFL, for instance, becomes more than 1 [M ohm] when CCFL is damaged.
- 1-4 Generally, CCFL has some amount of delay time after applying starting voltage. It is recommended to keep on applying starting voltage for **1 [Sec]** until discharge.
- 1-5 CCFL discharge frequency must be carefully chosen so as not to produce interfering noise stripes on the screen.
- 1-6 Reducing CCFL current increases CCFL discharge voltage and generally increases CCFL discharge frequency. So all the parameters of an inverter should be carefully designed so as not to produce too much leakage current from high-voltage output of the inverter.



Product Specification

AU OPTRONICS CORPORATION B156XW01

Note 1: It should be employed the inverter which has "Duty Dimming", if ICCFL is less than 4mA.

Note 2: CCFL discharge frequency should be carefully determined to avoid interference between inverter and TFT LCD.

Note 3: The frequency range will not affect to lamp life and reliability characteristics.

Note 4: **The output voltage of inverter should be able to give out a power after ballast capacitor , the generating capacity have to be larger than a lamp startup voltage**, otherwise backlight may has blinking for a moment after turns on or can not be turned on.

Note 5: Calculator value for reference ($ICCFL \times VCCFL = PCCFL$)

Note 6: Requirements for a system inverter design, which is intended to have a better display performance, a better power efficiency and a more reliable lamp, are following.

It shall help increase the lamp lifetime and reduce leakage current.

a. The asymmetry rate of the inverter waveform should be less than 10%.

b. The distortion rate of the waveform should be within $\sqrt{2} \pm 10\%$.

* Inverter output waveform had better be more similar to ideal sine wave.

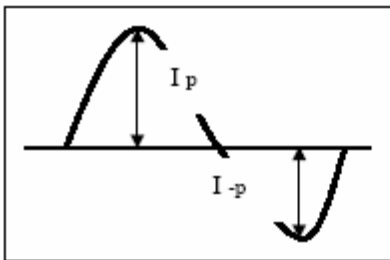

* Asymmetry rate:

$$\frac{|I_p - I_{-p}|}{I_{rms}} * 100\%$$

* Distortion rate

$$I_p \text{ (or } I_{-p}) / I_{rms}$$

Note 7: It is an edge-type BLU with single CCFL, the life-time define as the brightness decay to 50% of original value and under normal operation.



Product Specification

AU OPTRONICS CORPORATION B156XW01

6. Signal Characteristic

6.1 Pixel Format Image

Following figure shows the relationship of the input signals and LCD pixel format.

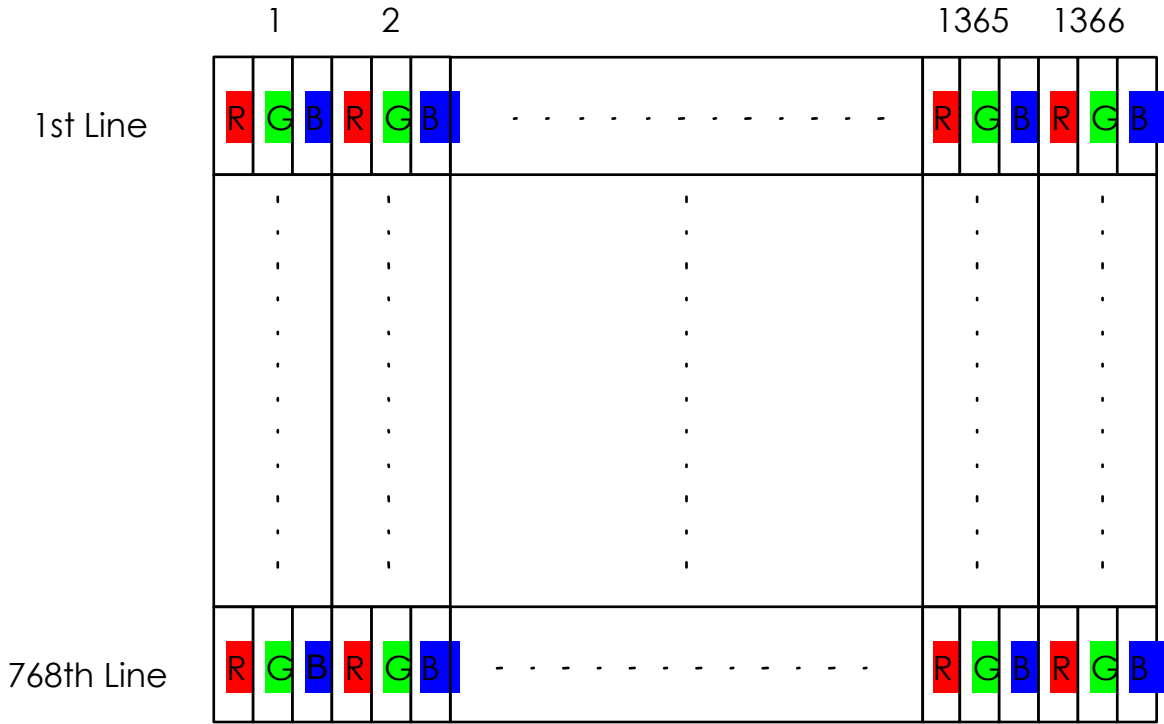



Product Specification

AU OPTRONICS CORPORATION B156XW01

6.2 The input data format

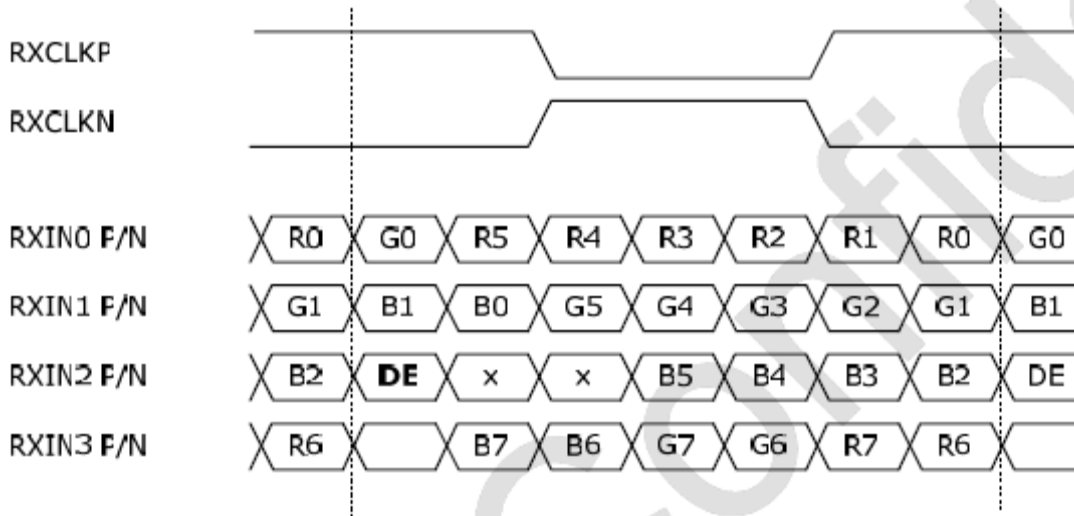

Signal Name	Description	
R5 R4 R3 R2 R1 R0	Red Data 5 (MSB) Red Data 4 Red Data 3 Red Data 2 Red Data 1 Red Data 0 (LSB) Red-pixel Data	Red-pixel Data Each red pixel's brightness data consists of these 6 bits pixel data.
G5 G4 G3 G2 G1 G0	Green Data 5 (MSB) Green Data 4 Green Data 3 Green Data 2 Green Data 1 Green Data 0 (LSB) Green-pixel Data	Green-pixel Data Each green pixel's brightness data consists of these 6 bits pixel data.
B5 B4 B3 B2 B1 B0	Blue Data 5 (MSB) Blue Data 4 Blue Data 3 Blue Data 2 Blue Data 1 Blue Data 0 (LSB) Blue-pixel Data	Blue-pixel Data Each blue pixel's brightness data consists of these 6 bits pixel data.
RxCLKIN	Data Clock	The typical frequency is 77.8 MHz. The signal is used to strobe the pixel data and DSPTMG signals. All pixel data shall be valid at the falling edge when the DSPTMG signal is high.
DE	Display Timing	This signal is strobed at the falling edge of -DTCLK. When the signal is high, the pixel data shall be valid to be displayed.
VS	Vertical Sync	The signal is synchronized to -DTCLK .
HS	Horizontal Sync	The signal is synchronized to -DTCLK .

Note: Output signals from any system shall be low or High-Z state when VDD is off.



Product Specification

AU OPTRONICS CORPORATION B156XW01

6.3 Signal Description/Pin Assignment

LVDS is a differential signal technology for LCD interface and high speed data transfer device.

PIN #	SIGNAL NAME	DESCRIPTION
1	VSS	Power Ground
2	VDD	+ 3.3V Power Supply
3	VDD	+ 3.3V Power Supply
4	V _{EDID}	+ 3.3V EDID Power
5	AGING	Aging Mode Power Supply
6	CLK _{EDID}	EDID Clock Input
7	DATA _{EDID}	EDID Data Input
8	RXIN0N	-LVDS Differential Data Input
9	RXIN0P	+LVDS Differential Data Input
10	VSS	Power Ground
11	RXIN1N	-LVDS Differential Data Input
12	RXIN1P	+LVDS Differential Data Input
13	VSS	Power Ground
14	RXIN2N	-LVDS Differential Data Input
15	RXIN2P	+LVDS Differential Data Input
16	VSS	Power Ground
17	CK1INN	-LVDS Differential Clock Input
18	CK1INP	+LVDS Differential Clock Input
19	VSS	Power Ground
20	X	---
21	X	---
22	VSS	Power Ground
23	X	---
24	X	---
25	VSS	Power Ground
26	X	---
27	X	---
28	VSS	Power Ground
29	X	---
30	X	---



Product Specification

AU OPTRONICS CORPORATION B156XW01

Note1: Start from right side

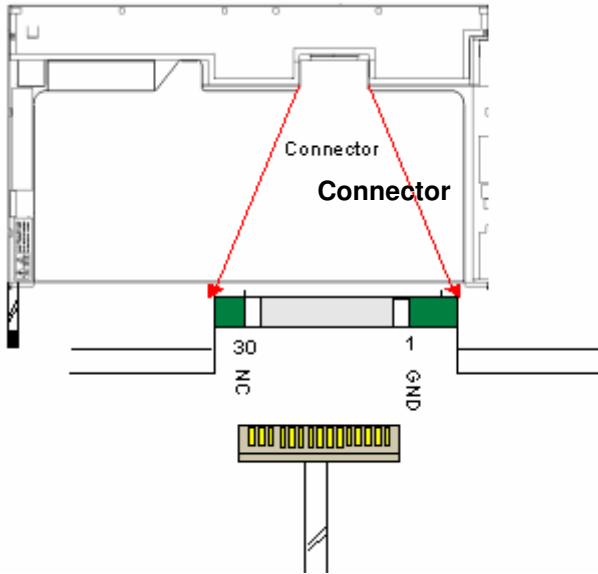

Note2: Input signals shall be low or High-impedance state when VDD is off.
internal circuit of LVDS inputs are as following.

The module uses a 100ohm resistor between positive and negative data lines of each receiver input

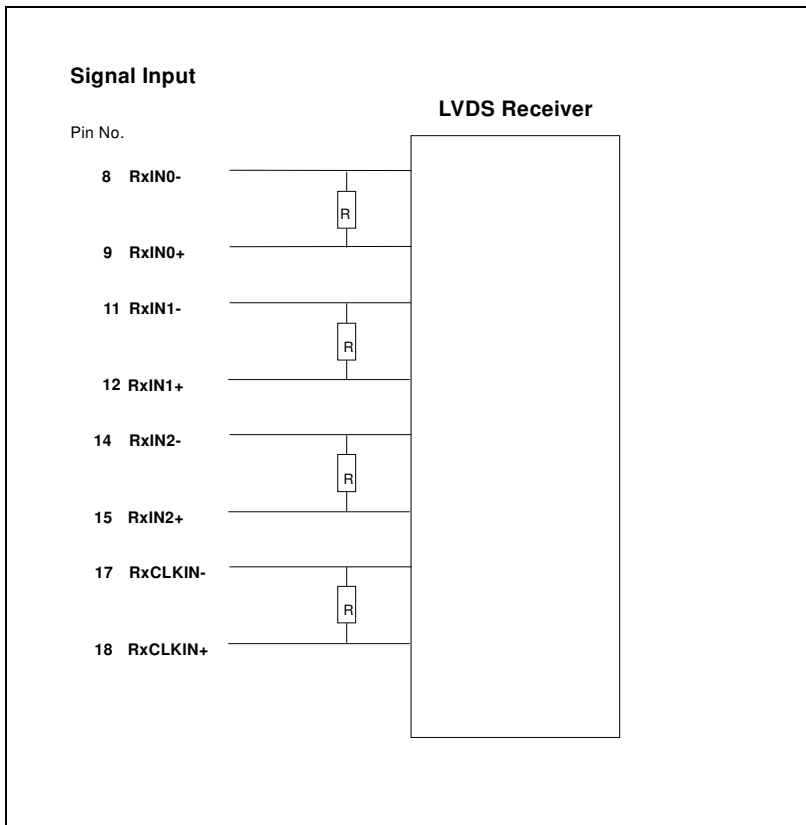



Product Specification

AU OPTRONICS CORPORATION B156XW01

6.4 Interface Timing

6.4.1 Timing Characteristics

Basically, interface timings should match the 1366x768 /60Hz manufacturing guide line timing.

Parameter	Symbol	Min.	Typ.	Max.	Unit	
Frame Rate	-	-	60	-	Hz	
Clock frequency	1/ T _{clock}	65	77.8	90	MHz	
Vertical Section	Period	T _V	776	808	1023	T _{Line}
	Active	T _{VD}	768	768	768	
	Blanking	T _{VB}	8	40	255	
Horizontal Section	Period	T _H	1396	1606	2047	T _{clock}
	Active	T _{HD}	1366	1366	1366	
	Blanking	T _{HB}	30	240	681	

Note : DE mode only



Product Specification

AU OPTRONICS CORPORATION B156XW01

6.4.2 Timing diagram

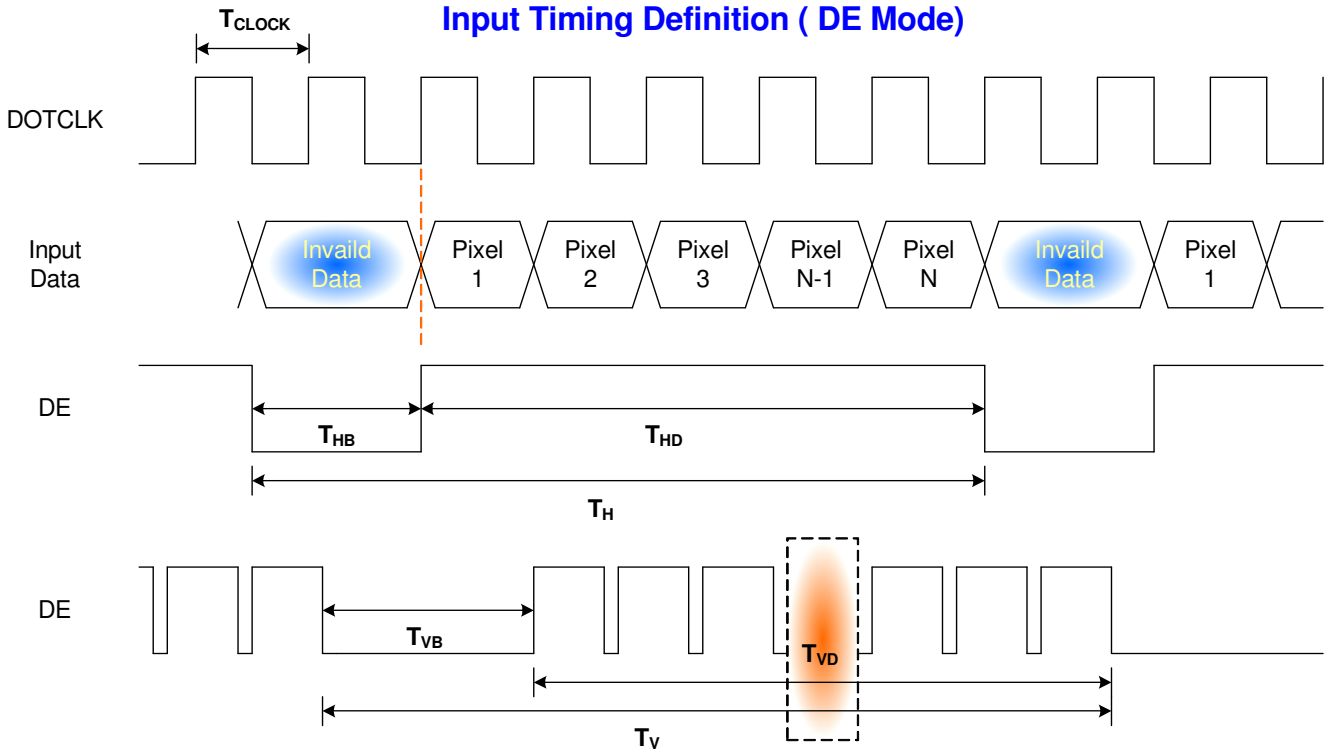



Product Specification

AU OPTRONICS CORPORATION B156XW01

6.5 Power ON/OFF Sequence

VDD power and lamp on/off sequence is as follows. Interface signals are also shown in the chart. Signals from any system shall be Hi-Z state or low level when VDD is off.

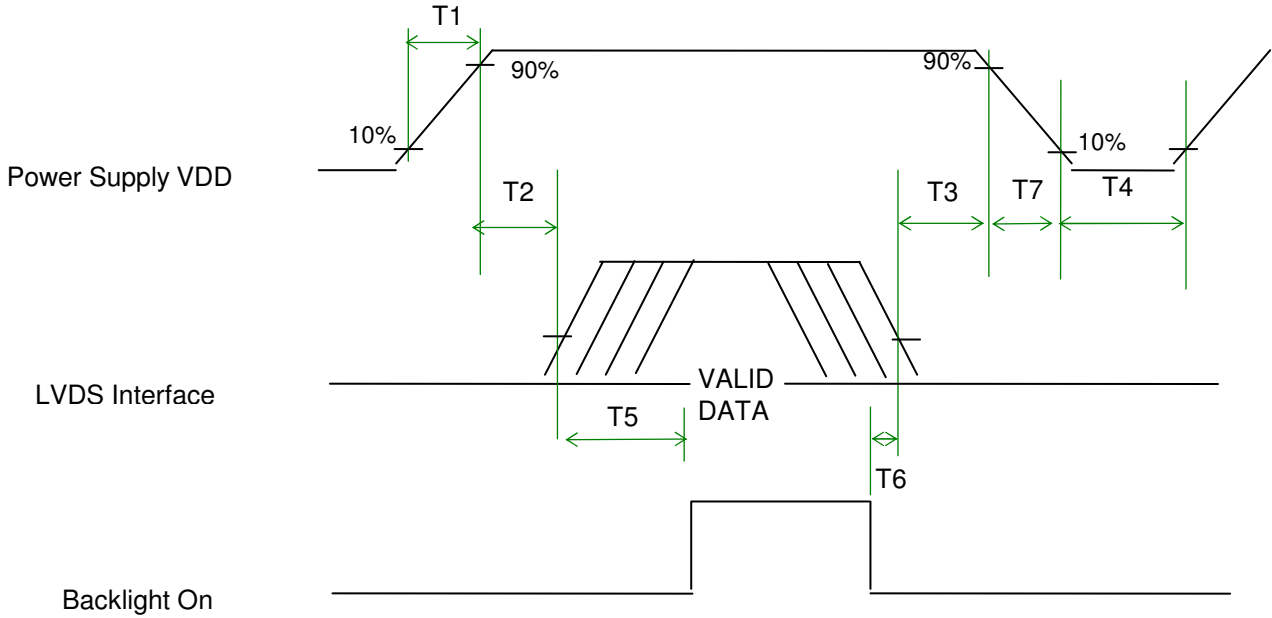

Timing

Parameter	Value			Units
	Min.	Typ.	Max.	
T1	0.5	-	10	(ms)
T2	0	-	50	(ms)
T3	0	-	50	(ms)
T4	400	-	-	(ms)
T5	200	-	-	(ms)
T6	200	-	-	(ms)
T7	0	-	10	(ms)

Power Sequence



Product Specification

AU OPTRONICS CORPORATION B156XW01

7. Connector Description

Physical interface is described as for the connector on module.

These connectors are capable of accommodating the following signals and will be following components.

7.1 TFT LCD Module

Connector Name / Designation	For Signal Connector
Manufacturer	JAE or compatible
Type / Part Number	JAE, FI-XB30SL-HF10
Mating Housing/Part Number	

7.2 Backlight Unit

Physical interface is described as for the connector on module.

These connectors are capable of accommodating the following signals and will be following components.

Connector Name / Designation	For Lamp Connector
Manufacturer	JST
Type / Part Number	BHSR-02VS-1
Mating Type / Part Number	SM02B-BHSS-1-TB

7.3 Signal for Lamp connector

Pin #	Cable color	Signal Name
1	Pink	Lamp High Voltage
2	White	Lamp Low Voltage



8. Dynamic Test

8.1 Vibration Test

Test condition:

- Acceleration: 1.5 G
- Frequency: 10 - 500Hz Random
- Sweep: 30 Minutes each Axis (X, Y, Z)

8.2 Shock Test Spec:

Test condition:

- Acceleration: 220 G , Half sine wave
- Active time: 2 ms
- Pulse: +/-X,+/-Y,+/-Z , one time for each side

Remark:

1. Ambient condition is $25 \pm 5^{\circ}\text{C}$, Relative humidity : 40% ~ 70%
2. Non-packaged and Non-operation



Product Specification

AU OPTRONICS CORPORATION B156XW01

9. Reliability

Items	Required Condition	Note
Temperature Humidity Bias	Ta= 40°C, 90%RH, 300h	
High Temperature Operation	Ta= 50°C, Dry, 300h	
Low Temperature Operation	Ta= 0°C, 300h	
High Temperature Storage	Ta= 60°C, 35%RH, 300h	
Low Temperature Storage	Ta= -20°C, 50%RH, 300h	
Thermal Shock Test	Ta=-20°C to 60°C, Duration at 30 min, 100 cycles	
ESD	Contact : ±8 KV Air : ±15 KV	Note 1

Note1: According to EN 61000-4-2 , ESD class B: Some performance degradation allowed. No data lost . Self-recoverable. No hardware failures.

Remark: MTBF (Excluding the CCFL): 30,000 hours with a confidence level 90%



Product Specification

AU OPTRONICS CORPORATION B156XW01

10. Mechanical Characteristics

10.1 LCM Outline Dimension

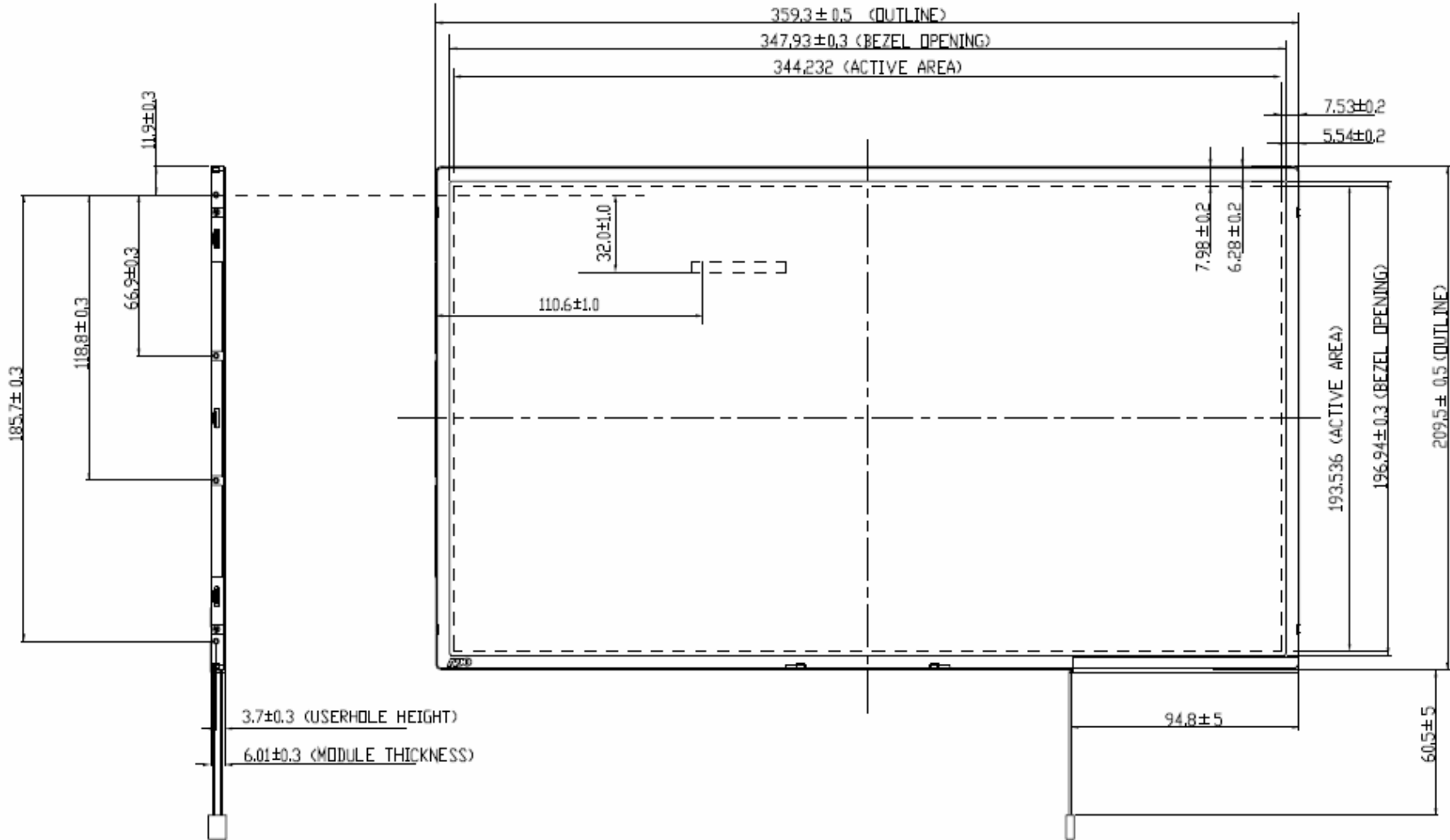



Product Specification

AU OPTRONICS CORPORATION B156XW01

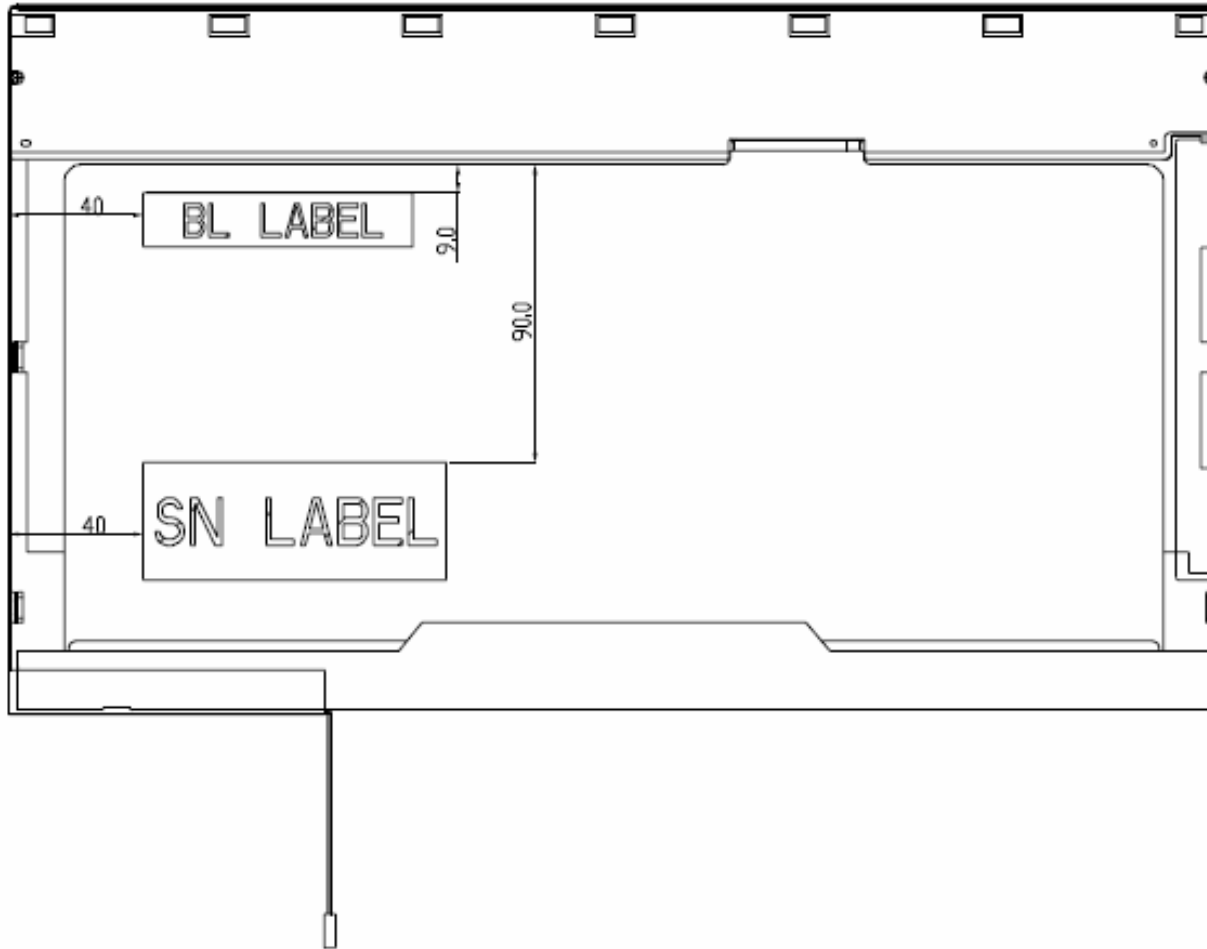



Product Specification

AU OPTRONICS CORPORATION B156XW01

10.2 Screw Hole Depth and Center Position

Screw hole minimum depth, from side surface = 2.6 mm (See drawing)

Screw hole center location, from front surface = 3.7 ± 0.3 mm (See drawing)

Screw maximum length = 2.3 mm (See drawing)

Screw Torque: Maximum 2.5 kgf-cm



Product Specification

AU OPTRONICS CORPORATION B156XW01

11. Shipping and Package

11.1 Shipping Label Format

 XXXXXXXXXXXXXXXX-XXXXXX	Manufactured 05/52 Model No: B156XW01 VO AU Optronics OAXX6 MADE IN CHINA (S3) H/W: 0A F/W:1	 
 CT: CXXXXXXXXXXXX		



Product Specification

AU OPTRONICS CORPORATION B156XW01

11.2 Carton package

The outside dimension of carton is TBD

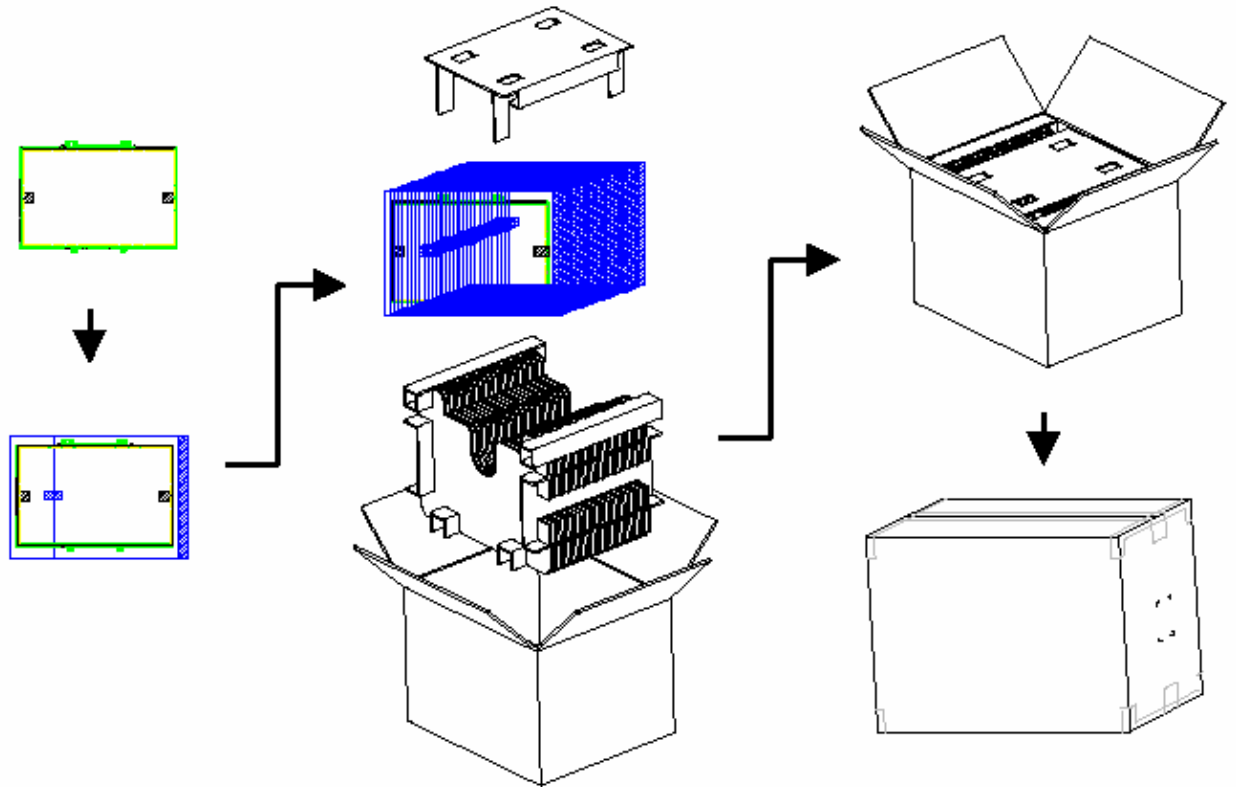

11.3 Shipping package of palletizing sequence

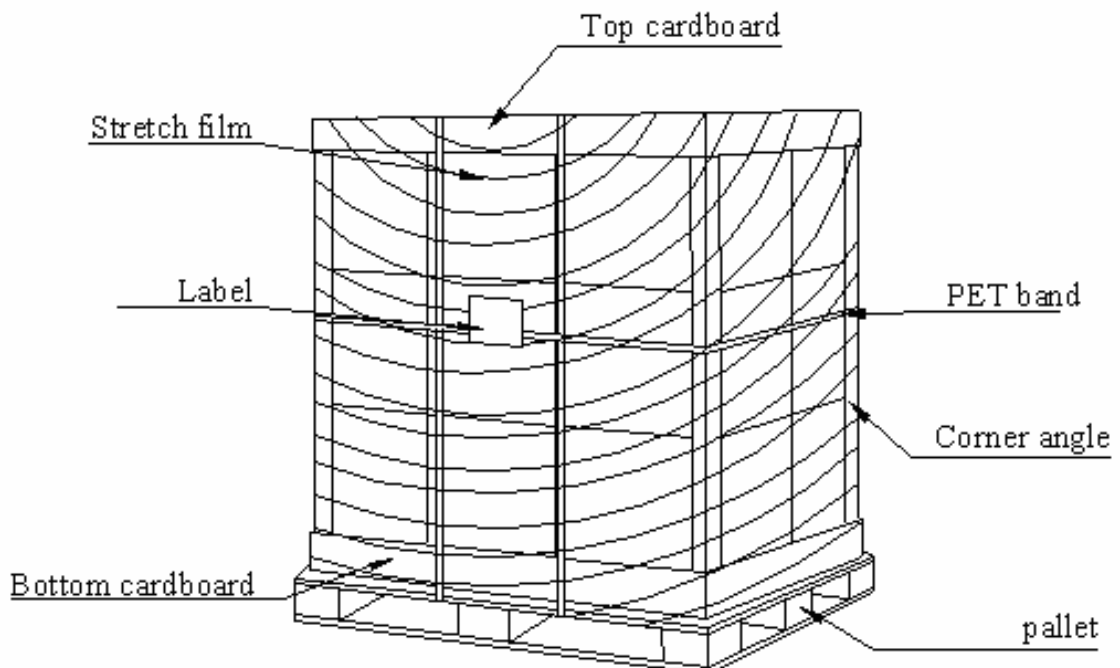



Product Specification

AU OPTRONICS CORPORATION B156XW01

12. Appendix: EDID description

TBD