



Chunghwa Picture Tubes, Ltd.

Technical Specification

To :
Date : 2008/04/30

CPT TFT-LCD

CLAA154WB05A N

ACCEPTED BY :

APPROVED BY	CHECKED BY	PREPARED BY
黃奕凱	劉益群	申珮君

Prepared by : TFT-LCD Application Division
CHUNGHWA PICTUER TUBES, LTD.

1127 Hopin Rd., Padeh, Taoyuan, Taiwan 334, R.O.C.
TEL: +886-3-3675151 FAX: +886-3-377-3003

Doc. No:	CLAA154WB05A N	Issue Date:	2008/04/30
----------	----------------	-------------	------------

1. OVERVIEW

CLAA154WB05A Nis 15.4" color (39.116cm) TFT-LCD (Thin Film Transistor Liquid Crystal Display) module composed of LCD panel, LVDS driver ICs, control circuit and backlight. By applying 6 bit digital data, 1280×RGB(3)×800, 262K-color images are displayed on the 15.4" diagonal screen. General specifications are summarized in the following table :

ITEM	SPECIFICATION
Display Area (mm)	331.2 (H)×207.0 (V) (15.4-inch diagonal)
Number of Pixels	1280 ×3(H)×800(V)
Pixel Pitch (mm)	0.25875(H)×0.25875(V)
Color Pixel Arrangement	RGB vertical stripe
Display Mode	Normally white
Number of Colors	262,144(6bits)(RSDS)
Gamut	50%(typ) : 45%(min)
Optimum Viewing Angle	6 o'clock
Response Time (ms)	16ms
Viewing Angle	40°、40°/10°、30°(Min.)
Brightness (cd/m ²)	200 cd/m ² (5point)/6 mA (Typ.) 170 cd/m ² (5point)/6 mA (Min.)
Uniformity	5point : 80% 13point : 75%
Consumption of Power (W)	7W (Max)
Module Size (mm)	344.5(W)×222.5(H)×6.2(D) (Max)
Module Weight (g)	585 (max)

The LCD Products listed on this document are not suitable for use of aerospace equipment, submarine cable, and nuclear reactor control system and life support systems. If customers intend to use these LCD products for applications listed above or those not included in the "Standard" list as follows, please contact our sales in advance.

Standard : Computer, Office equipment, Communication equipment, Test and Measurement equipment, Machine tool, Industrial robot, Audio and Visual equipment, Other consumer products.

2. ABSOLUTE MAXIMUM RATINGS

The following are maximum value, which if exceeded, may cause faulty operation or damage to the unit.

ITEM	SYMBOL	MIN.	MAX.	UNIT	REMARK
Power Supply Voltage for LCD	VCC	0	4.0	V	
Lamp voltage	VL	700	945	Vrms	
Lamp current	IL	3	6.5	mArms	*1). 2)
Lamp frequency	FL	50	80	kHz	
Operation Temperature	Top	0	50	°C	*3). 4). 5). 6)
Storage Temperature	Tstg	-25	65	°C	*3). 4). 5)
Delayed Discharge Time	TD	--	1	sec	*7)

【Note】

- *1) Product life-time relate to lamp current, please operate production follow statement at page 9 “(b)back light” .
- *2) When lamp current over the definition of absolute max. ,product life-time will decay rapidly or operate unusual.
- *3) The relative temperature and humidity range are as below sketch, 90%RH Max. ($T_a \leq 40^\circ\text{C}$)
- *4) The maximum wet bulb temperature $\leq 39^\circ\text{C}$ ($T_a > 40^\circ\text{C}$) and without dewing.
- *5) If product in environment which over the definition of the relative temperature and humidity out of range too long, it will affect visual of LCD.
- *6) If you operate LCD in normal temperature range, the center surface of panel should be under 60°C .
- *7) Delay discharge time test condition : starting lamp voltage=1650Vrms.(please follow statement at page 9 “(b)back light”

Before test TD, lamp should operate at least 1min, and lamp current should follow typical lamp current specification. To place panel at room temp. ($25 \pm 2^\circ\text{C}$) below for 24hrs., and then to measure TD with the same starting lamp voltage in dark room.

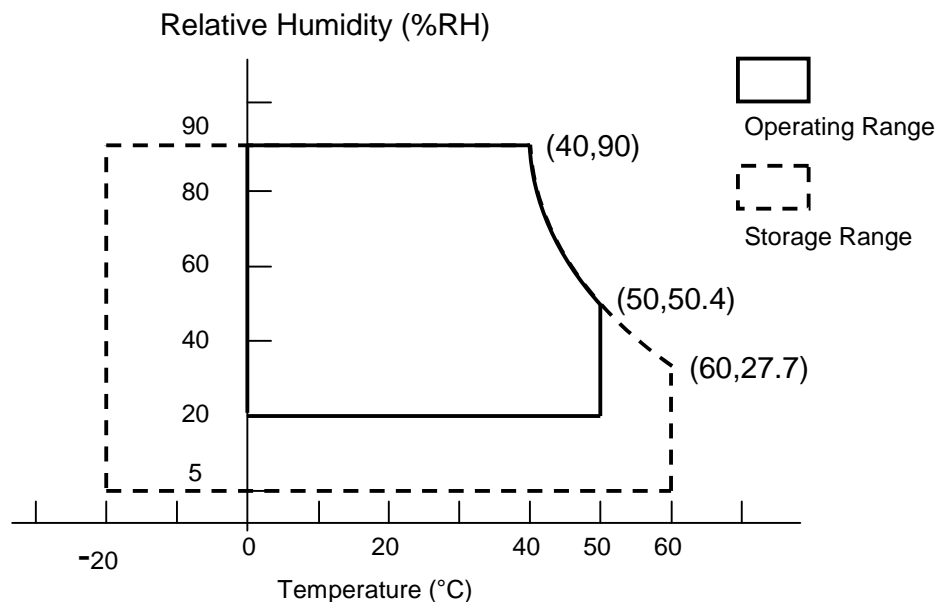

3. ELECTRICAL CHARACTERISTICS

(A) TFT LCD

TEM	SYMBOL	MIN	TYP	MAX	UNIT	REMARK	
LCD POWER VOLTAGE	VCC	3.0	3.3	3.6	V	[Note 1]	
LCD POWER CURRENT	ICC	-	400	600	mA	[Note 2]	
Rush CURRENT	Irush	-	-	2	A	[Note 3]	
LOGIC INPUT VOLTAGE (LVDS: IN+,IN-) [Note 3]	INPUT VOLTAGE	VIN	0	-	VCC	V	
	COMMON VOLTAGE	VCM	1.125	1.25	1.375	V	
	DIFFERENTIAL INPUT VOLTAGE	VID	250	350	450	mV	
	THRESHOLD VOLTAGE (HIGH)	VTH	-	-	100	mV	When VCM = +1.2V
	THRESHOLD VOLTAGE (LOW)	VTL	-100	-	-	mV	
DIFFERENTIAL INPUT VOLTAGE TOLERANCE	Δ VID	-	-	35	mV		
COMMON VOLTAGE TOLERANCE	Δ VCM	-	-	35	mV		

[Note 1] Power Sequence :

$t1 \leq 10\text{ms}$	$1 \text{ sec} \leq t5$
$0.01 \text{ ms} < t2 \leq 50 \text{ ms}$	$200 \text{ ms} \leq t6$
$0.01 \text{ ms} < t3 \leq 50 \text{ ms}$	$200 \text{ ms} \leq t7$
$0.01 \text{ ms} < t4 \leq 10 \text{ ms}$	

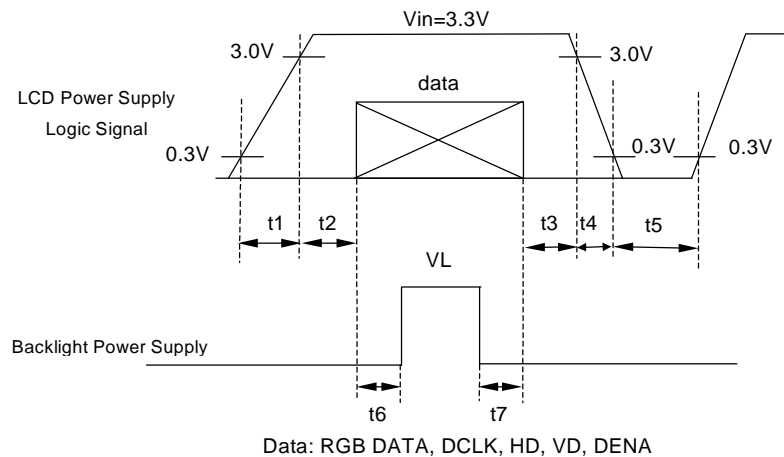

VCC-dip state

(1)when $3.0 > VCC \geq 2.7V$, $t_d \leq 10$ ms

(2)when $VCC < 2.7V$, VCC-dip condition should as the VCC-turn-off condition.

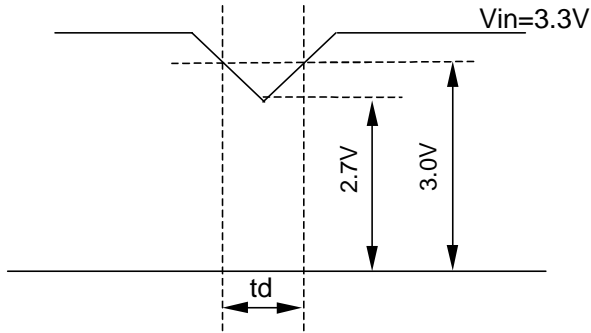

[Note 2]

Typical value is 0~63 gray level.(horizontal line Pattern)

800 line mode , VCC= +3.3V

Circuit condition(Typ.)

VCC=3.3 V , $f_v=60$ Hz $f_H=48.9$ kHz , $f_{CLK}=68.9$ MHz

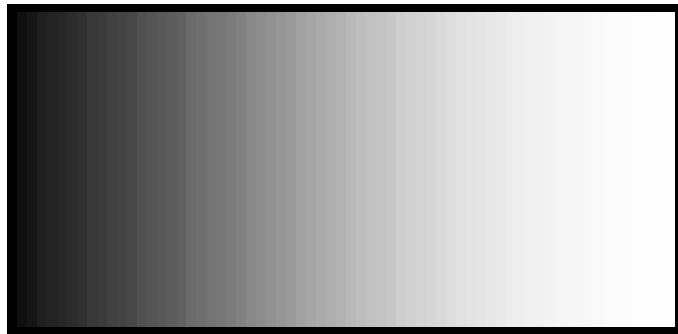

64-Gray :
0 ~ 63 Gray

Circuit condition(MAX.)

VCC=3.3 V , $f_v=60$ Hz $f_H=48.9$ kHz , $f_{CLK}=68.9$ MHz

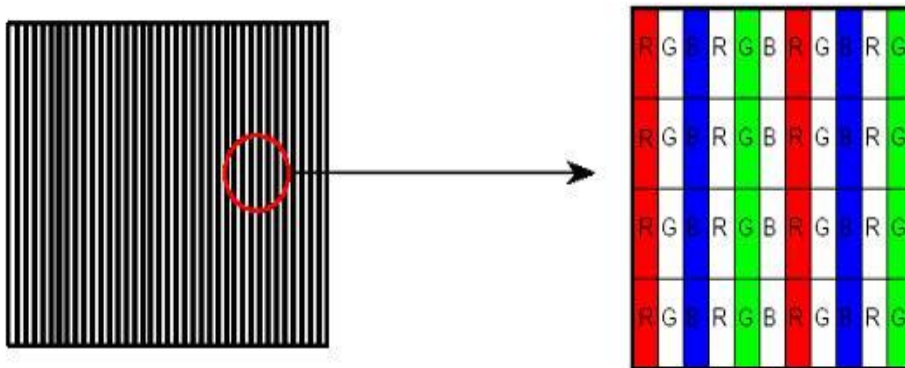

[Note 3]

LVDS Signal Definite :

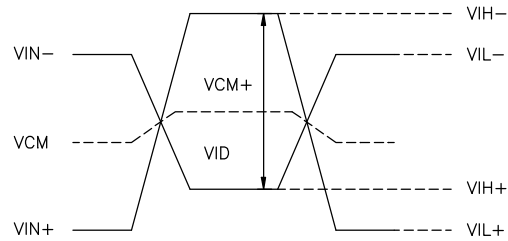
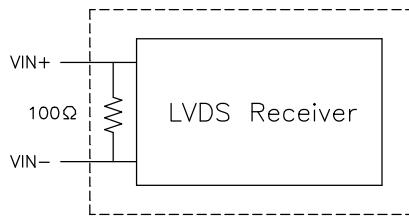

VIN+ : Positive differential DATA & CLK Input
VIN- : Negative differential DATA & CLK Input

$$VID = VIN_+ - VIN_-$$

$$\Delta VCM = | VCM_+ - VCM_- |$$

$$\Delta VID = | VID_+ - VID_- |$$

$$VID_+ = | VIH_+ - VIL_+ |$$

$$VID_- = | VIL_- - VIH_- |$$

$$VCM = (VIN_+ + VIN_-) / 2$$

$$VCM_+ = (VIH_+ + VIH_-) / 2$$

$$VCM_- = (VIL_+ + VIL_-) / 2$$

4) Refer to Inverter rated voltage

[Note 4] Irush measure condition

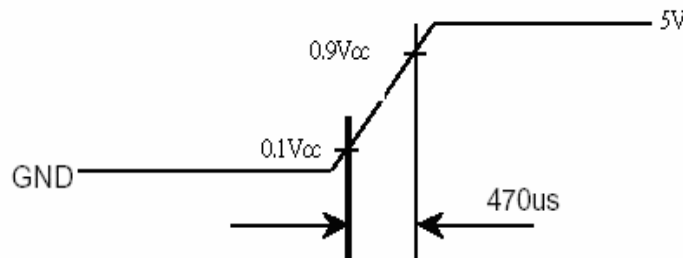
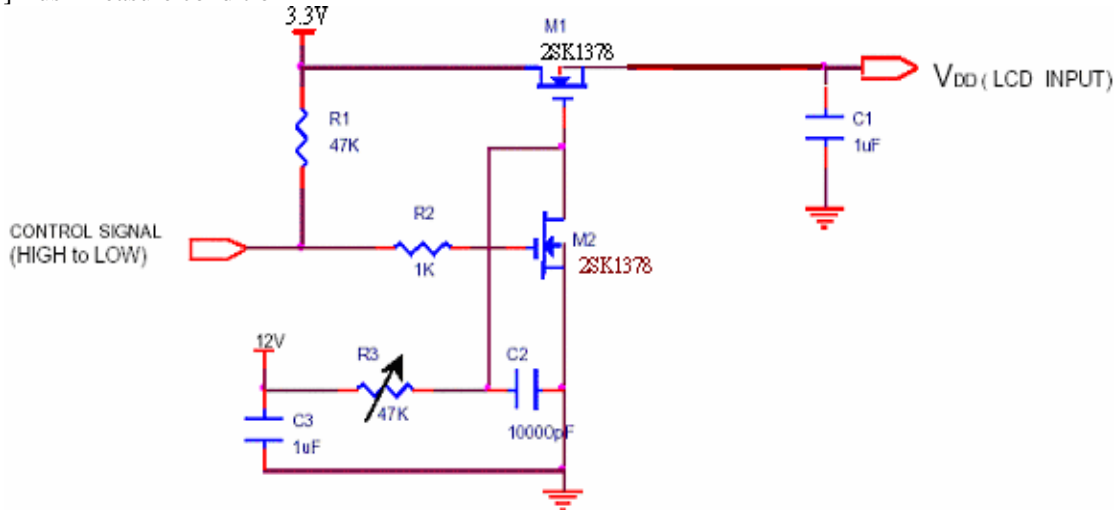

(B) BACK LIGHT

(a.) ELECTRICAL CHARACTERISTICS

Ta=25°C

ITEM	SYMBOL	MIN	TYP	MAX	UNIT	REMARK
Lamp Voltage(IL=6.0mA)	VL	657	700	803	Vrms	IL=6.0mA
Lamp Current	IL	3	6.0	6.5	mArms	*1)
Inverter Frequency	FI	50	--	60	kHz	*2)
Lamp Initial Voltage	VS	1460	--		Vrms	Ta=25°C
		1730	--		Vrms	Ta=0°C

(b) LAMP LIFE – TIME

ITEM	IL at 2.0 mA	IL at 6.0 mA	IL at 6.5 mA	單位	備註
LAMP LIFE-TIME (LT)	Min. 15,000	Min. 15,000	Min.10,000	hr	Continuous Operation*3)
Turn-on and turn-off Operation	--	Min.100,000	--	times	Continuous Operation *4)

*1)Measure method : galvanometer connect to low voltage

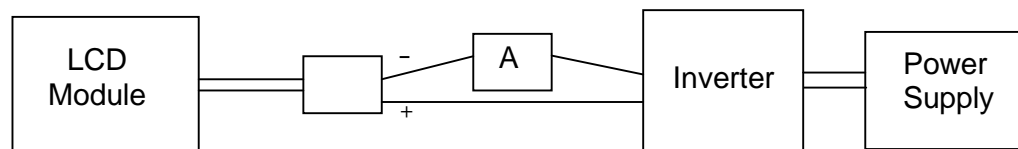

*2)Frequency in this range can make the characteristics of electric and optics maintain in +/- 10% except hue.

Lamp frequency of inverter may produce interference with horizontal synchronous frequency, and this may cause horizontal beat on the display. Therefore, please adjust lamp frequency, and keep inverter as far from module as possible or use electronic shielding between inverter and module to avoid the interference.

Under optimum operate frequency range (50~80 KHz), will not effect panel life-time and reliability .

*3) Definition of the lamp life time :

- Luminance (L) under 50% of specification starting lamp voltage
- Starting Lamp Voltage: over 130% of the initial value. Ta=25°C

*4) For keeping good lighting situation ,when design the inverter,it must be considered that the voltage large than starting lamp voltage.

*5) $WL=IL \times VL \circ (IL=6mA \cdot Ta=25^\circ C)$

4.Connector Interface PIN & Function

(a) CN1(Interface signal)

Outlet connector: FI-XB30SL-HF10 (JAE) , AL2304-A0G1D-P(P-TWO)

Link connector: FI-X30H (JAE, Link Type)

(Note) DDC: Display Data Requirements

(Note)Refer to page6、7、8、9之 Data Mapping

Pin No.	SYMBOL	FUNCTION
1	Vss	Ground
2	Vin	+3.3V Power
3	Vin	+3.3V Power
4	V_EDID	DDC 3.3V Power
5	NC	No Connect
6	CLK_EDID	DDC Clock
7	DATA_EDID	DDC Data
8	R0N	minus signal of channel 0(LVDS)
9	R0P	plus signal of channel 0(LVDS)
10	Vss	Ground
11	R1N	minus signal of channel 1(LVDS)
12	R1P	plus signal of channel 1(LVDS)
13	Vss	Ground
14	R2N	minus signal of channel 2(LVDS)
15	R2P	plus signal of channel 2(LVDS)
16	Vss	Ground
17	RCLKN	minus signal of clock channel (LVDS)
18	RCLKP	plus signal of clock channel (LVDS)
19	Vss	Ground
20	NC	No connect
21	NC	VCOM test provided , but customer-end unused (open)
22	NC	No connect
23	NC	No connect
24	NC	No connect
25	NC	No connect
26	NC	No connect
27	NC	No connect
28	NC	No connect
29	NC	No connect
30	NC	No connect

(b) CN2 (BACKLIGHT)

Backlight-side connector: BHSR-02VS-1 (JST)

Inverter-side connector: SM02B-BHSS-1 (JST)

Pin No.	Symbol	Function
1	CTH	VBLH (High)
2	CTL	VBLL (Low)

[Note] : VBLH-VBLL=VL

5. INTERFACE TIMING CHART

(a) LVDS input time sequence

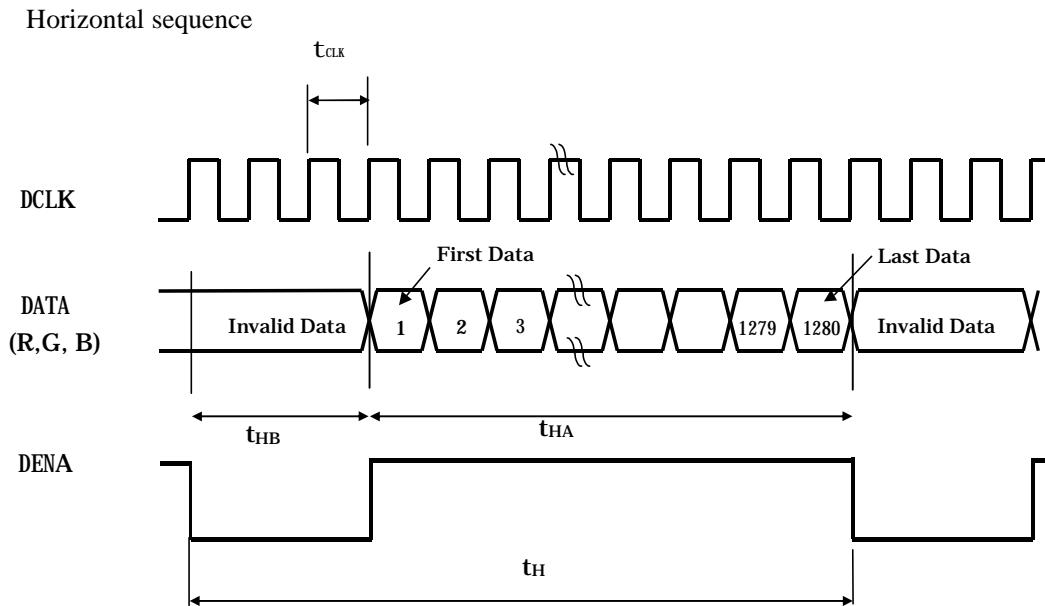

(b) LCD input time sequence

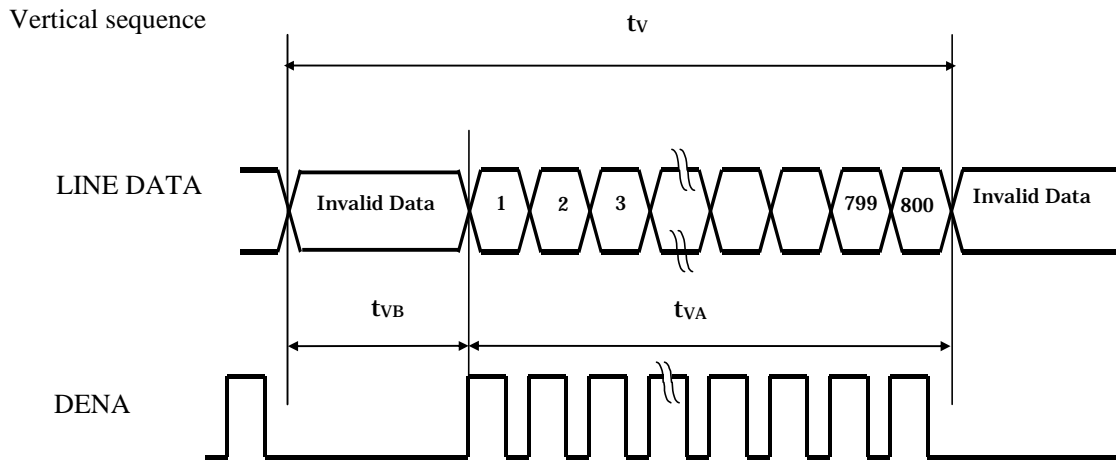

(1) Timing Chart

項目		SYMBOL	MIN	TYP	MAX	UNIT		
LCD Timing	DCLK	Frequency	f_{CLK}	65.3	68.9	74.7	MHz	
		Period	t_{CLK}	15.3	14.5	13.3	ns	
	DENA	Horizontal	Horizontal total time	t_H	1344	1408	1500	t_{CLK}
			Horizontal Active time	t_{HA}	1280	1280	1280	t_{CLK}
			Horizontal Blank time	t_{HB}	64	128	220	t_{CLK}
	DENA	Vertical	Vertical total time	t_V	810	816	830	t_H
			Vertical Active time	t_{VA}	800	800	800	t_H
			Vertical Blank time	t_{VB}	10	16	30	t_H

[Note]

- *1) Data is latched during DCLK falling period.
- *2) HD、VD is negative.
- *3) DENA (DATA ENABLE) usually is positive.
- *4) During the whole blank period, DCLK should keep input.
During the vertical blank period, HD should keep input.

(2) DATA mapping

Color	Input Data	R DATA						G DATA						B DATA					
		R5	R4	R3	R2	R1	R0	G5	G4	G3	G2	G1	G0	B5	B4	B3	B2	B1	B0
		MS B					LS B	MS B					LS B	MS B					LS B
Basic Color	Black	0	0	0	0	0	0	0	0	0	0	0	0	0	0	0	0	0	0
	Red(63)	1	1	1	1	1	1	0	0	0	0	0	0	0	0	0	0	0	0
	Green(63)	0	0	0	0	0	0	1	1	1	1	1	1	0	0	0	0	0	0
	Blue(63)	0	0	0	0	0	0	0	0	0	0	0	0	1	1	1	1	1	1
	Cyan	0	0	0	0	0	0	1	1	1	1	1	1	1	1	1	1	1	1
	Magenta	1	1	1	1	1	1	0	0	0	0	0	0	1	1	1	1	1	1
	Yellow	1	1	1	1	1	1	1	1	1	1	1	1	0	0	0	0	0	0
	White	1	1	1	1	1	1	1	1	1	1	1	1	1	1	1	1	1	1
RED	RED(0)	0	0	0	0	0	0	0	0	0	0	0	0	0	0	0	0	0	0
	RED(1)	0	0	0	0	0	1	0	0	0	0	0	0	0	0	0	0	0	0
	RED(2)	0	0	0	0	1	0	0	0	0	0	0	0	0	0	0	0	0	0
	RED(62)	1	1	1	1	1	0	0	0	0	0	0	0	0	0	0	0	0	0
	RED(63)	1	1	1	1	1	1	0	0	0	0	0	0	0	0	0	0	0	0
Green	Green(0)	0	0	0	0	0	0	0	0	0	0	0	0	0	0	0	0	0	0
	Green(1)	0	0	0	0	0	0	0	0	0	0	0	1	0	0	0	0	0	0
	Green(2)	0	0	0	0	0	0	0	0	0	0	1	0	0	0	0	0	0	0
	Green(62)	0	0	0	0	0	0	1	1	1	1	1	0	0	0	0	0	0	0
	Green(63)	0	0	0	0	0	0	1	1	1	1	1	1	0	0	0	0	0	0
Blue	Blue(0)	0	0	0	0	0	0	0	0	0	0	0	0	0	0	0	0	0	0
	Blue(1)	0	0	0	0	0	0	0	0	0	0	0	0	0	0	0	0	0	1
	Blue(2)	0	0	0	0	0	0	0	0	0	0	0	0	0	0	0	0	1	0
	Blue(62)	0	0	0	0	0	0	0	0	0	0	0	0	1	1	1	1	1	0
	Blue(63)	0	0	0	0	0	0	0	0	0	0	0	0	1	1	1	1	1	1

[Note]

- 1) Gray level:
Color(n) : n is level order; higher n means brighter level.
- 2) DATA:
1: high、0: low

6. BLOCK DIAGRAM

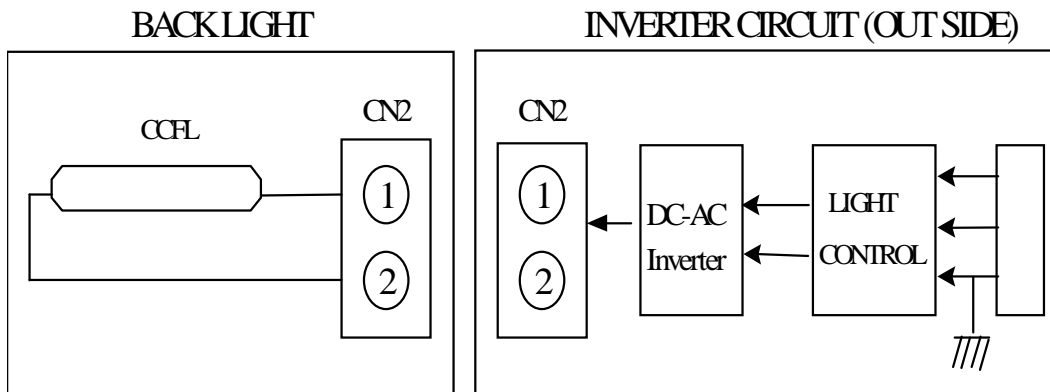
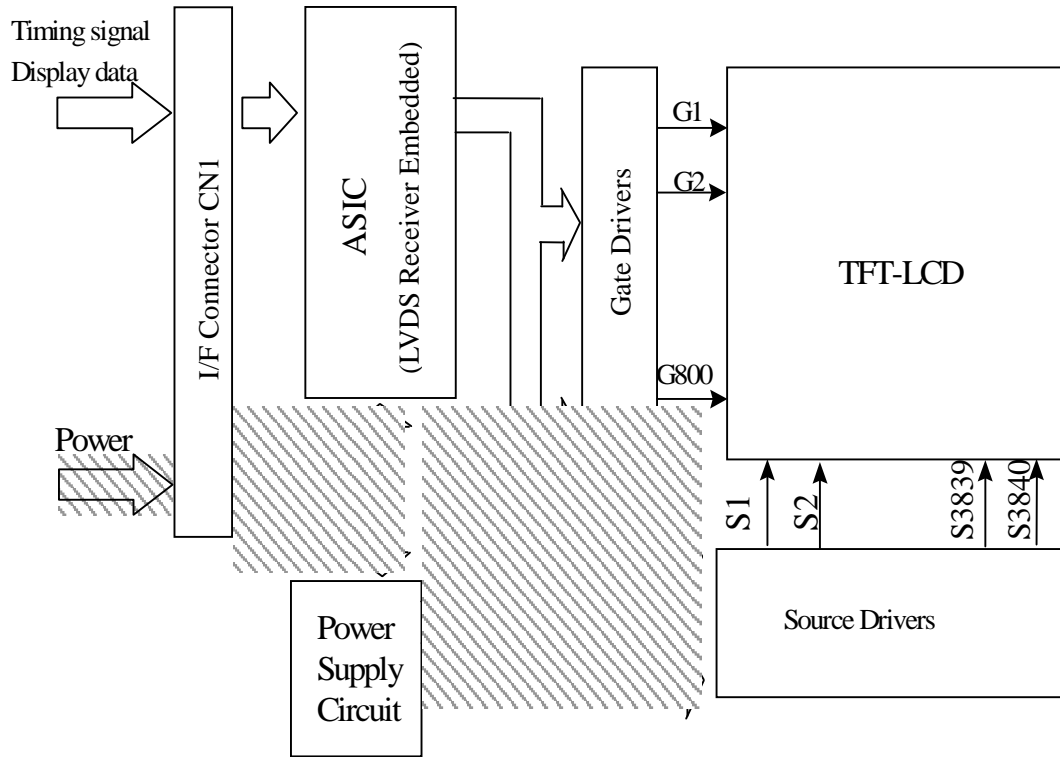

7. MECHANICAL SPECIFICATION

(1) Front side

The tolerance, not show in the figure, is $\pm 0.5\text{mm}$.

[Unit : mm]

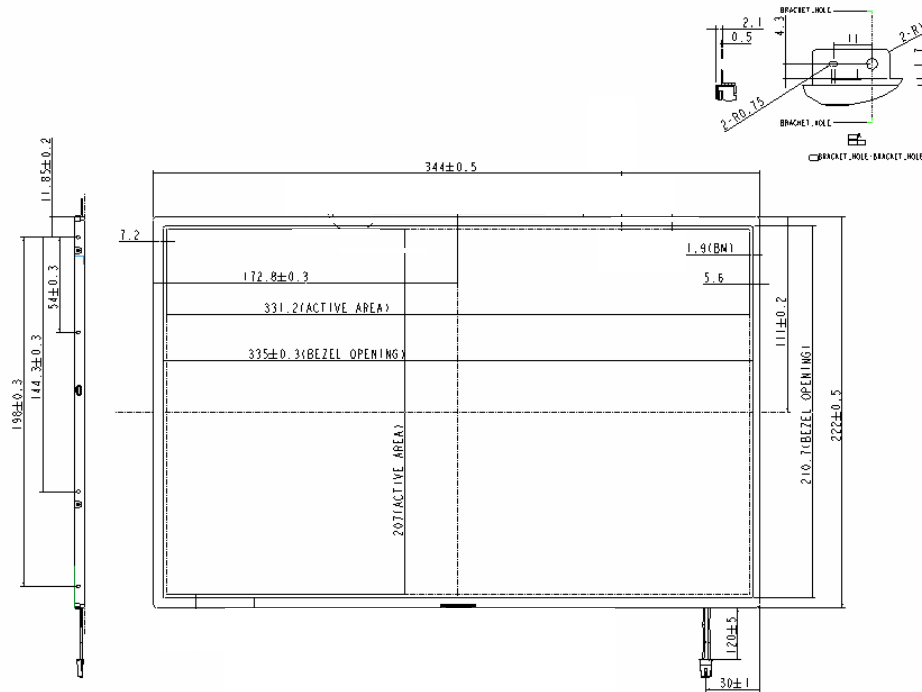

(2) Rear side

The tolerance, not show in the figure, is $\pm 0.5\text{mm}$.

[Unit : mm]

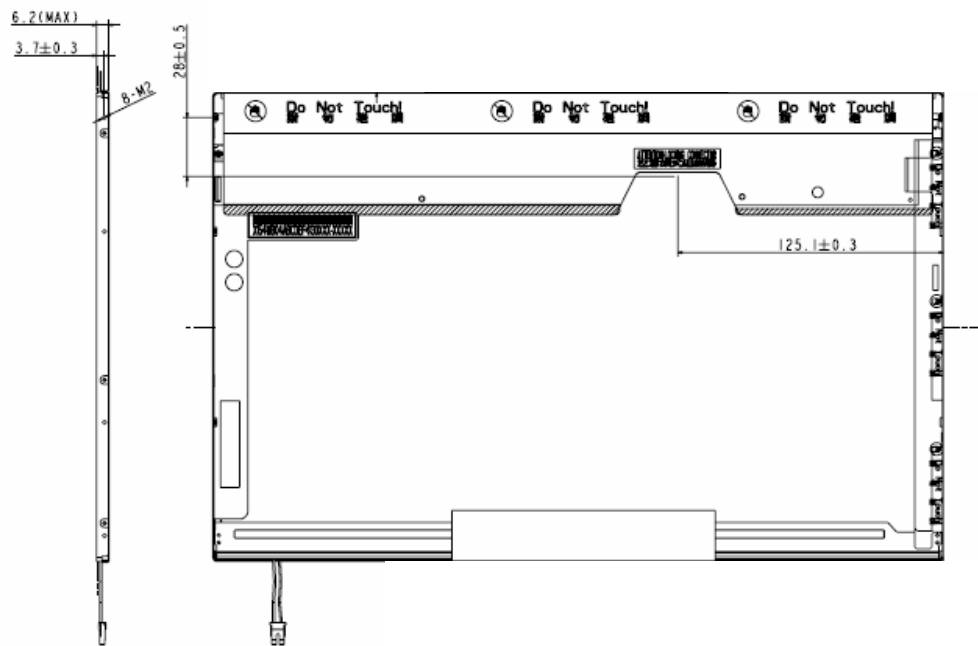

8. OPTICAL CHARACTERISTICS

Ta=25°C , VDD=3.3V

ITEM	SYMBOL	CONDITION	MIN.	TYP.	MAX.	UNIT	REMARK	
Contrast Ratio	CR	$\theta = \psi = 0^\circ$	300	500	--	--	*1)	
Luminance (5P)	L	$\theta = \psi = 0^\circ$	170	200	--	cd/m ²	*2)	
Uniformity(5P)	ΔL	$\theta = \psi = 0^\circ$	--	80	--	%	*2)	
Response Time	Tr	$\theta = \psi = 0^\circ$	--	6	9	ms	*4)	
	Tf	$\theta = \psi = 0^\circ$	--	10	16	ms	*4)	
Cross talk	CT	$\theta = \phi = 0^{*3}$	--	--	1	%	*5)	
View angle	Horizont	ψ	CR ≥ 10	40/-40	45/-45	--	°	*3)
	Vertical	θ		10/-30	15/-35	--	°	*3)
Color Temperature Coordinate	W	X	$\theta = \psi = 0^\circ$	0.283	0.313	0.343	--	*2)
		Y		0.299	0.329	0.359		
	R	X		0.584	0.614	0.644		
		Y		0.306	0.336	0.366		
	G	X		0.281	0.311	0.341		
		Y		0.534	0.564	0.594		
	B	X		0.123	0.153	0.183		
		Y		0.100	0.130	0.160		

These items are measured using BM-5A (TOPCON) under the dark room condition (no ambient light).
Measurement Condition: IL=6.0×6mA

Inverter : SUMIDA / IV12139/T

Definition of these measurement items is as follows:

***1) Definition of Contrast Ratio**

CR=ON (White) Luminance/OFF (Black) Luminance

***2) Definition of Luminance and Luminance uniformity**

Central luminance: The white luminance is measured at the center position "5" on the screen, see Fig.1 below.

5P Luminance (AVG): The white luminance is measured at measuring points 5、10、11、12、13, see Fig.1 below.

5P Uniformity: $\Delta L = (L_{min} / L_{max}) \times 100\%$

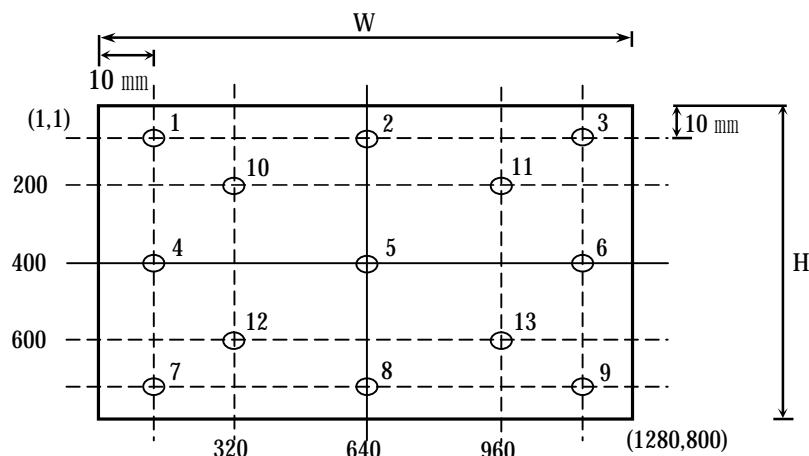
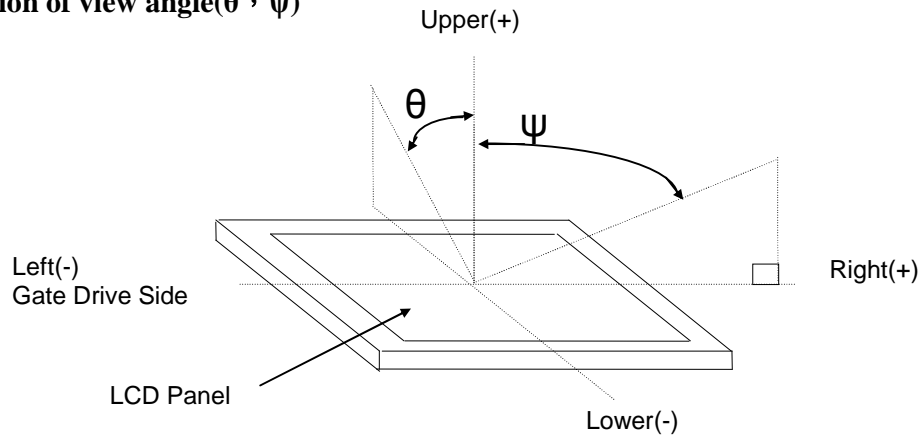
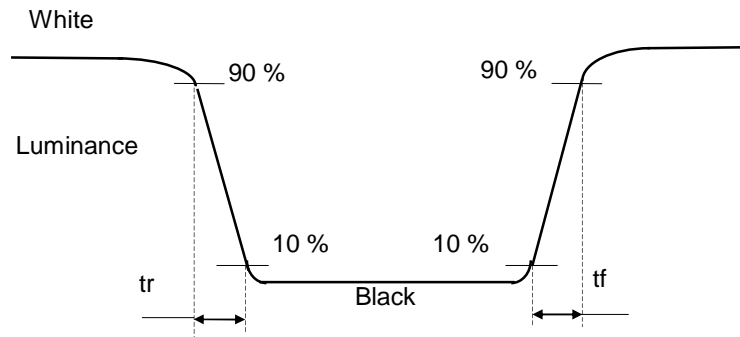

Fig.1 Measure

***3) Definition of view angle(θ , ψ)**



***4) Definition of response time**



***5) Crosstalk Modulation Ratio:**

$$CT = | Y_B - Y_A | / Y_A \times 100\%$$

Y_A 、 Y_B measure position and definition

Y_A means luminance at gray level 32(exclude gray level 0 pattern)

Y_B means luminance at gray level 32(include gray level 0 pattern)

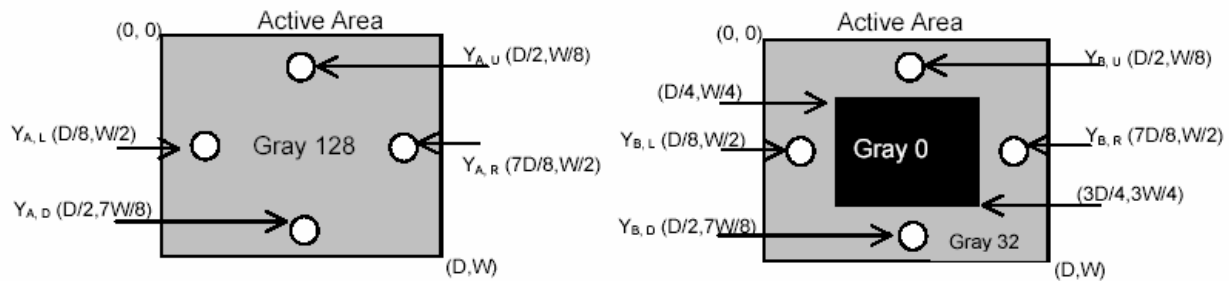

9.RELIABILITY TEST CONDITIONS**(1) Temperature and Humidity**

TEST ITEMS	CONDITIONS
High Temperature Operation	50° C ; 240HR Follow page 5 diagram
High Temperature Storage	60° C ; 240HR Follow page 5 diagram
High Temperature High Humidity Operation	240HR(No condensation) Follow page5 diagram
High Temperature High Humidity Storage	48HR(No condensation) Follow page5 diagram
Low Temperature Operation	0° C ; 240HR Follow page5 diagram
Low Temperature Storage	-20° C ; 240HR Follow page5 diagram
Thermal Shock	-20° C (0.5 hr) ~ 60° C (0.5 hr) , Ramp < 20° C , 100 CYCLE
Temperature & Pressure Storage	25° C ; 260hPa(about 10000m) , 24 Hrs

(2) Shock & Vibration

TEST ITEMS	CONDITIONS
Shock (Non-Operation)	Shock level : 1960m/s ² (200G), Waveform : half sinusoidal wave, 2ms, 6 axis (± X, ± Y, ± Z) per cycle
Vibration (Non-Operation)	Vibration level : 9.8m/s ² (1.0G), sinusoidal wave (each x,y,z axis : 1hr, total 3hrs) Frequency range : 5 ~ 500 Hz Sweep speed : 0.5 Octave/min.

(3) ESD

	Surface discharge(Panel display area , Frame , PWB , Panel back side)		Electrics capacity of Connector
	Contact	Air	Contact
Capacity	150 pF	150 pF	200 pF
Resistance	330 Ω	330 Ω	0 Ω
Voltage	±8kV	±8kV/±15kV	±250 V
Interval	1 sec	1 sec	1 sec
Times(single point)	25	25	1

Acceptance Criteria	Air Discharge	Air Discharge
	+/-8 kV	+/-15 kV
A	Permitted	Permitted
B	Permitted	Permitted
C	Not Permitted	Permitted
D	Not Permitted	Not Permitted

Acceptance Definitions	
A	Normal operation. No degradation. No failures.
B	Some performance degradation allowed. No data lost. Self-recoverable.
C	Temporary performance degradation. Recovery by operator is acceptable.
D	Degradation or loss of function, which is not recoverable due to damage of equipment (components)

(4) Judgment standard

The judgment of the above test should be made as follow:

Pass : Normal display image with no obvious non-uniformity and no line defect.

Partial transformation of the module parts should be ignored.

Fail : No display image, obvious non-uniformity, or line defects.

10. VISUAL INSPECTION SPECIFICATION

10.1 Inspection condition

- (1) Viewing distance is approximately 35 ~ 40 cm.
- (2) Viewing angle is normal to the LCD panel as figure below(10°).
- (3) Ambient temperature is approximately $25 \pm 5^{\circ}\text{C}$.
- (4) Ambient humidity is $60 \pm 5\%$ RH.
- (5) Ambient illumination is from 300 ~ 500 lux.
- (6) Input signal timing should be typical value.

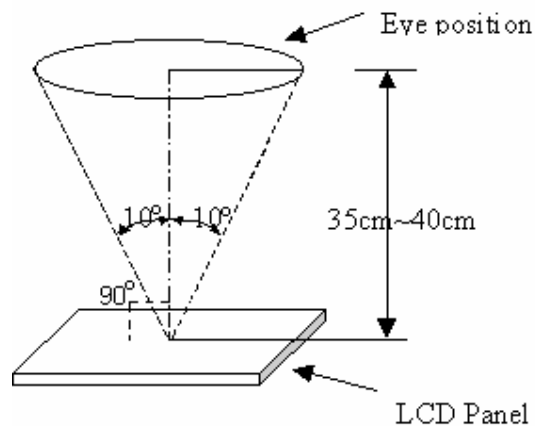

10.2 Special condition

- (1) Viewing distance is close for inspection of adjacent dots and distance between defect dots.
- (2) Viewing condition of “ Shot block non-uniformity from oblique angle” is as figure below.
- (3) Exceptional case: View angle $\pm 40^{\circ}$ while inspected image-sticking.

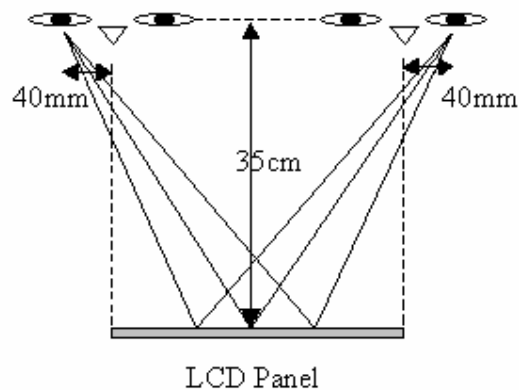

10.3 Inspection Criteria

DEFECT TYPE		LIMIT		Note	
VISUAL DEFECT	SCRATCH		$0.01\text{mm} \leq W \leq 0.05\text{mm}$ $L \leq 10\text{mm}$	$N \leq 4$ --	
	INTERNAL	SPOT	$0.15\text{mm} \leq \phi \leq 0.5\text{mm}$	$N \leq 4$ *1)	
		FIBER	$W \leq 0.1\text{mm}, L \leq 3.0\text{mm}$	$N \leq 4$ *1)	
		POLARIZER BUBBLE	$0.15\text{mm} \leq \phi \leq 0.5\text{mm}$	$N \leq 4$ *1)	
		TOTAL	$N \leq 4$		--
ELECTRICAL DEFECT	BRIGHT DOT		$N \leq 4$	*2)	
	DARK DOT		$N \leq 5$	--	
	TOTAL DOT		$N \leq 6$	*2)	
	TWO ADJACENT DOT		≤ 1 PAIRS	*3)	
	THREE OR MORE ADJACENT DOT		NOT ALLOWED		--
	DISTANCE BETWEEN DEFECT DOT		Bright dot and dark dot	$\geq 15\text{mm}$	*4)
			Two dark dots	$\geq 15\text{mm}$	*4)
	LINE DEFECT		NOT ALLOWED		--
	MURA		$\leq 5\%$ ND		

One pixel consists of 3 sub-pixels, including R,G, and B dot.(Sub-pixel = Dot)

[Note1] W : Width[mm], L : Length[mm], N : Number, ϕ : Average Diameter

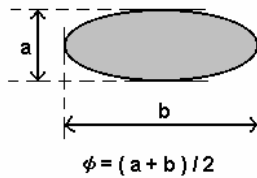

- 1. (White, black) Spot
- 2. Polarizer Bubble

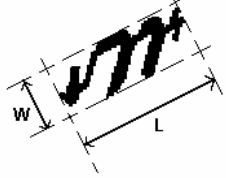

1. Fiber

[Note2] Bright dot is defined through 5% transmission ND Filter as following.

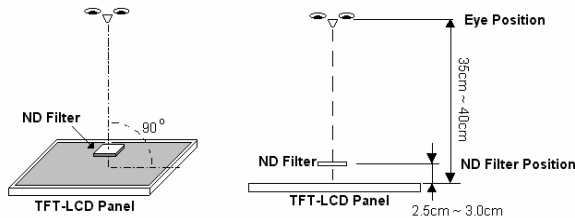

[Note3] Judge defect dot and adjacent dot as following. Allow below (as A, B, C and D status) adjacent defect dots, including bright and dark adjacent dot. And they will be counted 2 defect dots in total quantity.

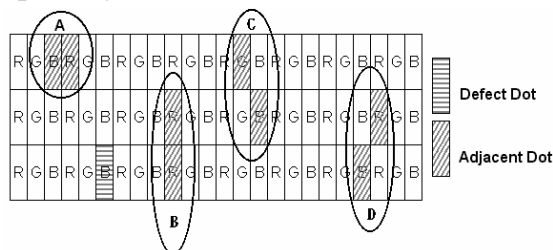

[Note4] Definition of distance between defect dot as following.

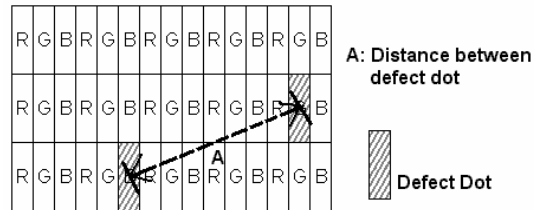

10.4 Handling precaution

- (1) Don't disassemble and reassemble the module by self. (禁止自行拆解。)
- (2) Acid, alkali, alcohol or touched directly by hand will damage the display.
(酸性、鹼性、酒精或手的直接接觸將會損傷顯示面。)
- (3) Static electricity will damage the module. Please configure grounding device.
(靜電會損傷模組。請裝配接地設備。)
- (4) The strong vibration, shock, twist or bend will cause material damage, even module broken.
(強烈的衝擊、震動、扭轉或彎曲將會造成原材損傷，甚至面板破裂)
- (5) It is easy to cause image sticking while displaying the same pattern for very long time.
(長期顯示同一畫面亦造成影像殘留。)
- (6) The response time, brightness and performance will vary from different temperature.
(反應時間、亮度與均勻性會因溫度而有所變化)

11. HANDLING PRECAUTIONS FOR TFT-LCD MODULE

Please pay attention to the followings in handling- TFT-LCD products;

11.1 ASSEMBLY PRECAUTION

- (1) Please use the mounting hole on the module side in installing and do not beading or wrenching LCD in assembling. And please do not drop, bend or twist LCD module in handling.
- (2) Please design display housing in accordance with the following guidelines.
 - Housing case must be destined carefully so as not to put stresses on LCD all sides and not to wrench module. The stresses may cause non-uniformity even if there is no non-uniformity statically.
 - Keep sufficient clearance between LCD module back surface and housing when the LCD module is mounted. Approximately 1.0 mm of the clearance in the design is recommended taking into account the tolerance of LCD module thickness and mounting structure height on the housing.
 - When some parts, such as, FPC cable and ferrite plate, are installed underneath the LCD module, still sufficient clearance is required, such as 0.5mm. This clearance is, especially, to be reconsidered when the additional parts are implemented for EMI countermeasure.
 - Design the inverter location and connector position carefully so as not to give stress to lamp cable, or not to interface the LCD module by the lamp cable.
 - Keep sufficient clearance between LCD module and the others parts, such as inverter and speaker so as not to interface the LCD module. Approximately 1.0mm of the clearance in the design is recommended.
- (3) Please do not push or scratch LCD panel surface with any-thing hard. And do not soil LCD panel surface by touching with bare hands. (Polarizer film, surface of LCD panel is easy to be flawed.)
- (4) Please do not press any parts on the rear side such as source TCP, gate TCP, control circuit board and FPCs during handling LCD module. If pressing rear part is unavoidable, handle the LCD module with care not to damage them.
- (5) Please wipe out LCD panel surface with absorbent cotton or soft clothe in case of it being soiled.
- (6) Please wipe out drops of adhesives like saliva and water on LCD panel surface immediately. They might damage to cause panel surface variation and color change.
- (7) Please do not take a LCD module to pieces and reconstruct it. Resolving and reconstructing modules may cause them not to work well.
- (8) Please do not touch metal frames with bare hands and soiled gloves. A color change of the metal frames can happen during a long preservation of soiled LCD modules.
- (9) Please pay attention to handling lead wire of backlight so that it is not tugged in connecting with inverter.

11.2 OPERATING PRECAUTIONS

- (1) Please be sure to turn off the power supply before connecting and disconnecting signal input cable.
- (2) Please do not change variable resistance settings in LCD module. They are adjusted to the most suitable value. If they are changed, it might happen LCD does not satisfy the characteristics specification.
- (3) Please consider that LCD backlight takes longer time to become stable of radiation characteristics in low temperature than in room temperature.
- (4) A condensation might happen on the surface and inside of LCD module in case of sudden change of ambient temperature.
- (5) Please pay attention to displaying the same pattern for very long time. Image might stick on LCD. If then, time going on can make LCD work well.
- (6) Please obey the same caution descriptions as ones that need to pay attention to ordinary electronic parts.

11.3 PRECAUTIONS WITH ELECTROSTATICS

- (1) This LCD module use CMOS-IC on circuit board and TFT-LCD panel, and so it is easy to be affected by electrostatics. Please be careful with electrostatics by the way of your body connecting to the ground and so on.
- (2) Please remove protection film very slowly on the surface of LCD module to prevent from electrostatics occurrence.

11.4 STORAGE PRECAUTIONS

- (1) When you store LCDs for a long time, it is recommended to keep the temperature between 0 °C ~40°C without the exposure of sunlight and to keep the humidity less than 90% RH.
- (2) Please do not leave the LCDs in the environment of high humidity and high temperature such as 60 °C 90% RH.
- (3) Please do not leave the LCDs in the environment of low temperature; below -20°C.

11.5 SAFETY PRECAUTIONS

- (1) When you waste LCDs, it is recommended to crush damaged or unnecessary LCDs into pieces and wash them off with solvents such as acetone and ethanol, which should later be burned.
- (2) If any liquid leaks out of a damaged-glass cell and comes in contact with the hands, wash off thoroughly with soap and water.

11.6 OTHERS

- (1) A strong incident light into LCD panel might cause display characteristics' changing inferior because of polarizer film, color filter, and other materials becoming inferior. Please do not expose LCD module direct sunlight and strong UV rays.
- (2) Please pay attention to a panel side of LCD module not to contact with other materials in preserving it alone.
- (3) For the packaging box, please pay attention to the followings:
 - Packaging box and inner case for LCD are designed to protect the LCDs from the damage or scratching during transportation. Please do not open except picking LCDs up from the box.
 - Please do not pile them up more than 3 boxes. (They are not designed so.) And please do not turn over.
 - Please handle packaging box with care not to give them sudden shock and vibrations. And also please do not throw them up.
 - Packing box and inner case for LCDs are made of cardboard. So please pay attention not to get them wet. (Such like keeping them in high humidity or wet place can occur getting them wet.)