



Chunghwa Picture Tubes, Ltd.

Technical Specification

To :

Date : 2007/06/26

CPT TFT-LCD
CLAA 154WB08A D

ACCEPTED BY :

APPROVED BY	CHECKED BY	PREPARED BY
黃奕凱	劉益群	趙志方

Prepared by : Design General Division

CHUNGHWA PICTUER TUBES, LTD.

No. 1, Huaying Rd., Sanho Tsun, Lungtan Shiang, Taoyuan, Taiwan, 325, R.O.C.
TEL: +886-3-4805678 FAX: +886-3-4800589

Doc. No:	CLAA154WB08A D-STUDIO -V1- 2007/06/26	Issue Date:	2007/06/26
----------	--	-------------	------------

Title : CLAA154WB08A Technical Specification**1. OVERVIEW**

CLAA154WB08A is 15.4" color (39.116cm) TFT-LCD (Thin Film Transistor Liquid Crystal Display) module composed of LCD panel, LVDS driver ICs, control circuit and backlight. By applying 6 bit digital data, 1280×RGB(3)×800, 262K-color images are displayed on the 15.4" diagonal screen. Interface of data and control signals is Typ. Inverter for backlight is included in this module General specifications are summarized in the following table :

ITEM	SPECIFICATION
Display Area (mm)	331.2 (H) x 207.0 (V) (15.4-inch diagonal)
Number of Pixels	1280×3(H)×800(V)
Pixel Pitch (mm)	0.25875(H)×0.25875(V)
Color Pixel Arrangement	RGB vertical stripe
Display Mode	Normally white
Number of Colors	262,144(6bits)
Gamut	50%(typ) ; 45%(min)
Optimum Viewing Angle	6 o'clock
Response Time (ms)	16ms
Surface Treatment	Glare, 3H
Viewing Angle (L/R/U/D)	45°、45°/20°、35° (Typ.)
Brightness (cd/m ²)	220 cd/m ² (5point)/6.5 mA (Typ.) 200 cd/m ² (5point)/6.5 mA (Min.)
Uniformity (Min)	5point : 80% 13point : 65%
Consumption of Power (W)	7W (Max) (With Inverter)
Module Size (mm)	344.5(W)×222.5(H)×6.2(D) (Max)
Module Weight (g)	585 (max)

The LCD Products listed on this document are not suitable for use of aerospace equipment, submarine cable, and nuclear reactor control system and life support systems. If customers intend to use these LCD products for applications listed above or those not included in the "Standard" list as follows, please contact our sales in advance.

Standard : Computer, Office equipment, Communication equipment, Test and Measurement equipment, Machine tool, Industrial robot, Audio and Visual equipment, Other consumer products.

2. ABSOLUTE MAXIMUM RATINGS

CHUNGHWA PICTUER TUBES, LTD.

TECHNICAL SPECIFICATION

Doc. No : _____
 Version : V1
 Issue Date : 2007/06/26

Title : CLAA154WB08A Technical Specification

The following are maximum value, which if exceeded, may cause faulty operation or damage to the unit.

ITEM	SYMBOL	MIN.	MAX.	UNIT	REMARK
Power Supply Voltage for LCD	VCC	0	4.0	V	
Lamp voltage	VL	630	945	Vrms	
Lamp current	IL	2	6.5	mArms	*1). 2)
Lamp frequency	FL	40	80	kHz	
Operation Temperature	Top	0	50	°C	*3). 4). 5). 6)
Storage Temperature	Tstg	-25	65	°C	*3). 4). 5)
Delayed Discharge Time	TD	--	1	sec	*7)

【Note】

- *1) Product life-time relate to lamp current, please operate production follow statement at page 9 “(b)back light” .
- *2) When lamp current over the definition of absolute max, product life-time will decay rapidly or operate unusual.
- *3) The relative temperature and humidity range are as below sketch, 90%RH Max. ($T_a \leq 40^\circ\text{C}$)
- *4) The maximum wet bulb temperature $\leq 39^\circ\text{C}$ ($T_a > 40^\circ\text{C}$) and without dewing.
- *5) If product in environment which over the definition of the relative temperature and humidity out of range too long, it will affect visual of LCD.
- *6) If you operate LCD in normal temperature range, the center surface of panel should be under 60°C .
- *7) Delay discharge time test condition : Starting lamp voltage=1650Vrms. (please follow statement at page 9 “ (b) back light”

Before test TD, lamp should operate at least 1min, and lamp current should follow typical lamp current specification. To place panel at room temp. ($25 \pm 2^\circ\text{C}$) below for 24hrs, and then to measure TD with the same starting lamp voltage in dark room.

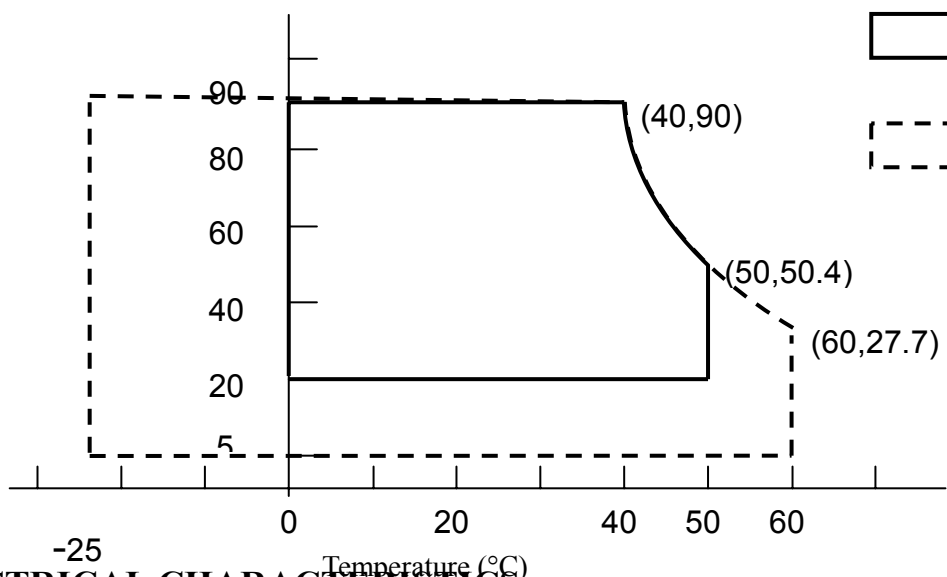

3. ELECTRICAL CHARACTERISTICS

(A) TFT LCD

CHUNGHWA PICTUER TUBES, LTD.

TECHNICAL SPECIFICATION

Doc. No : _____
 Version : V1
 Issue Date : 2007/06/26

Title : CLAA154WB08A Technical Specification

TEM	SYMBOL	MIN	TYP	MAX	UNIT	REMARK	
LCD POWER VOLTAGE	VCC	3.0	3.3	3.6	V	[Note 1]	
LCD POWER CURRENT	ICC	-	400	600	mA	[Note 2]	
Rush CRRENT	Irush	-	-	2	A	[Note 4]	
LOGIC INPUT VOLTAGE (LVDS: IN+,IN-) [Note 3]	INPUT VOLTAGE	VIN	0	-	VCC	V	
	COMMON VOLTAGE	VCM	1.125	1.25	1.375	V	
	DIFFRENTIAL INPUT VOLTAGE	VID	250	350	450	mV	
	THRESHOLD VOLTAGE (HIGH)	VTH	-	-	100	mV	When VCM = +1.2V
	THRESHOLD VOLTAGE (LOW)	VTL	-100	-	-	mV	
DIFFRENTIAL INPUT VOLTAGE TOLERANCE	ΔVID	-	-	35	mV		
COMMON VOLTAGE TOLERANCE	ΔVCM	-	-	35	mV		

[Note 1] Power Sequence :

- $t1 \leq 10\text{ms}$
- $0.01 \text{ ms} < t2 \leq 50 \text{ ms}$
- $0.01 \text{ ms} < t3 \leq 50 \text{ ms}$
- $1 \text{ sec} \leq t5$
- $200 \text{ ms} \leq t6$
- $200 \text{ ms} \leq t7$

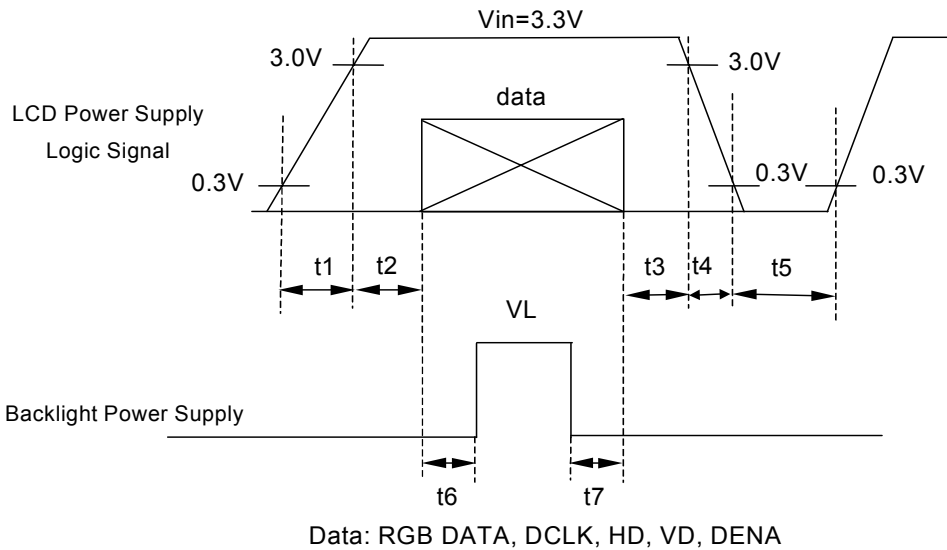

VCC-dip state

(1)when $3.0 > VCC \geq 2.7V$, $t_d \leq 10 \text{ ms}$

CHUNGHWA PICTUER TUBES, LTD.

TECHNICAL SPECIFICATION

Doc. No : _____
Version : V1
Issue Date : 2007/06/26

Title : CLAA154WB08A Technical Specification

(2)when $VCC < 2.7V$, VCC-dip condition should as the VCC-turn-off condition.

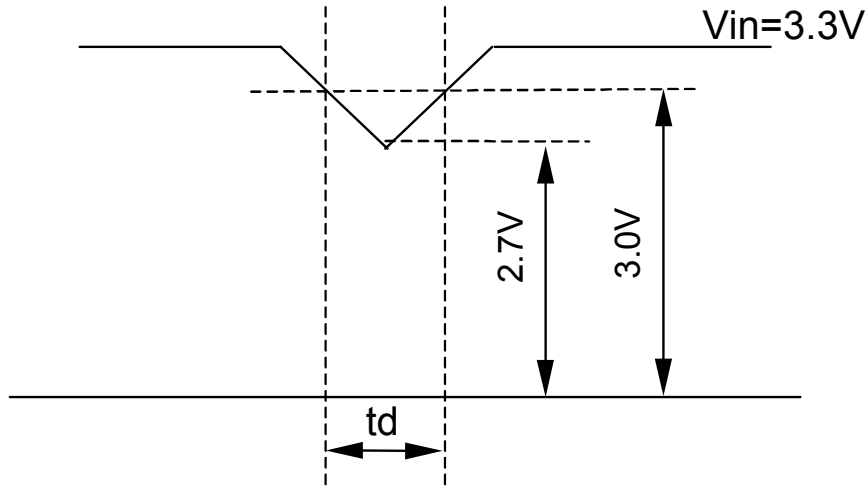

[Note 2]

Typical value is 0~63 gray level.(Horizontal line Pattern)

800 line mode , $VCC = +3.3V$

Circuit condition (Typ.)

$VCC = 3.3 V$, $f_V = 60 \text{ Hz}$, $f_H = 48.9 \text{ kHz}$, $f_{CLK} = 68.9 \text{ MHz}$

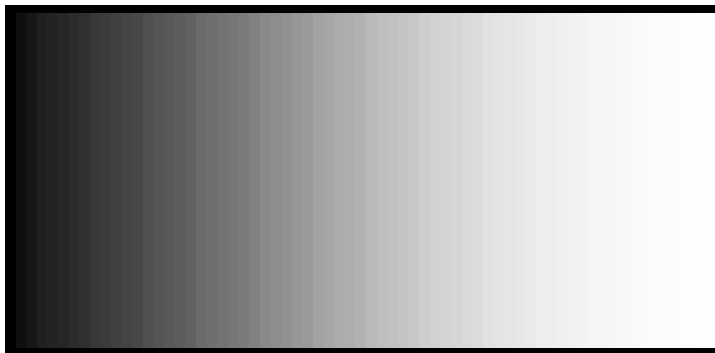

64-Gray:

Circuit condition (MAX.)

$VCC = 3.3 V$, $f_V = 60 \text{ Hz}$, $f_H = 48.9 \text{ kHz}$, $f_{CLK} = 68.9 \text{ MHz}$

Title : CLAA154WB08A

Technical Specification

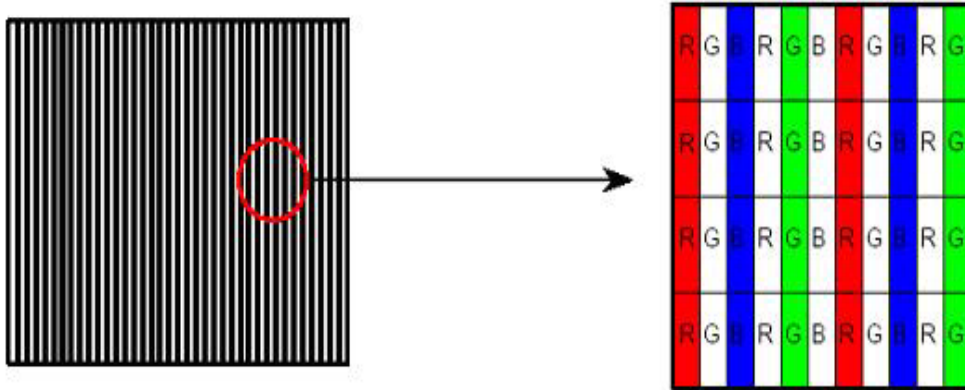

[Note 3] LVDS Signal Definite :

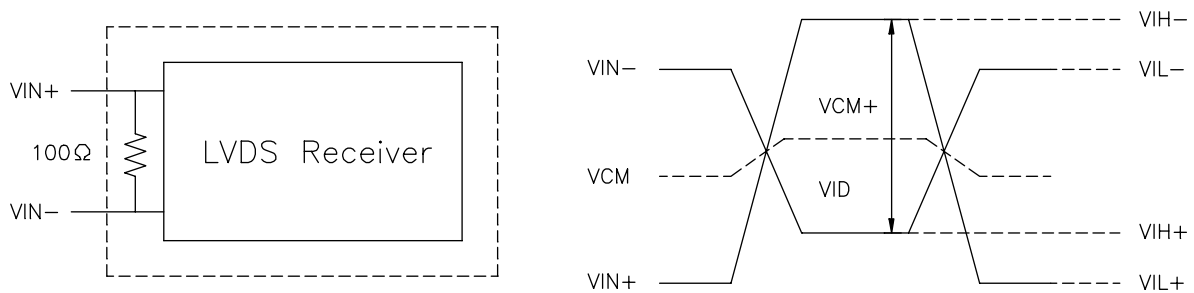

$$\begin{aligned}
 VID &= VIN+ - VIN-, \\
 \Delta VCM &= | VCM+ - VCM- |, \\
 \Delta VID &= | VID+ - VID- |, \\
 VID+ &= | VIH+ - VIH- |, \\
 VID- &= | VIL+ - VIL- |, \\
 VCM &= (VIN+ + VIN-)/2, \\
 VCM+ &= (VIH+ + VIH-)/2, \\
 VCM- &= (VIL+ + VIL-)/2,
 \end{aligned}$$

VIN+ : Positive differential DATA & CLK Input
 VIN- : Negative differential DATA & CLK Input

Refer to Inverter rated voltage
 [Note 4] Irush measure condition

Title : CLAA154WB08A

Technical Specification

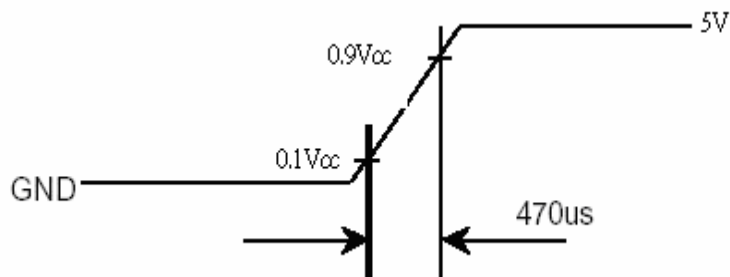
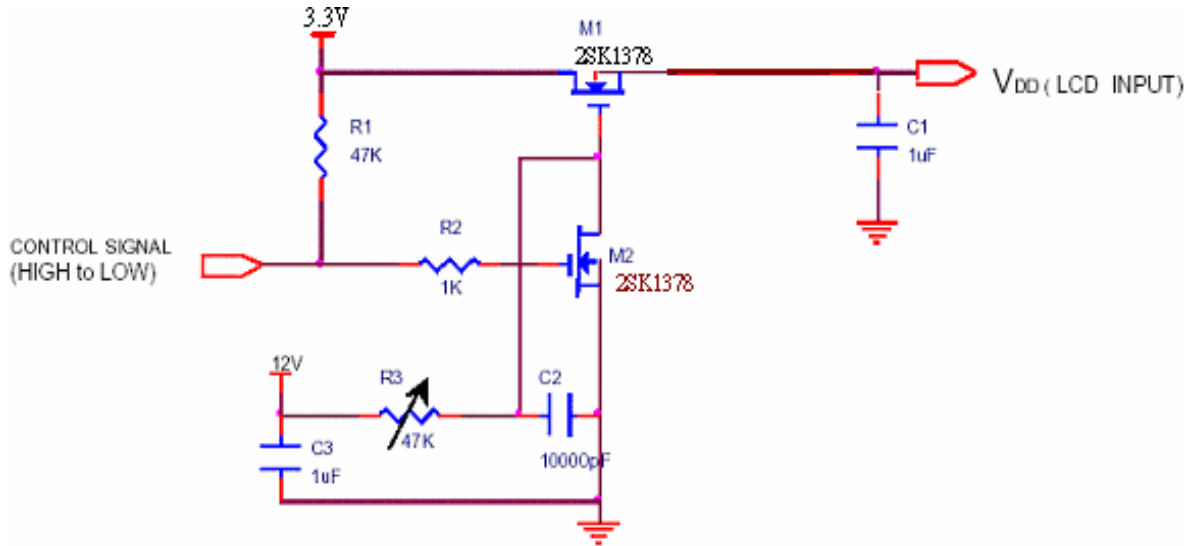

(B) BACK LIGHT

(a.) ELECTRICAL CHARACTERISTICS

CHUNGHWA PICTUER TUBES, LTD.

TECHNICAL SPECIFICATION

Doc. No : _____
 Version : V1
 Issue Date : 2007/06/26

Title : CLAA154WB08A Technical Specification

Lamp:

Ta=25°C

ITEM	SYMBOL	MIN	TYP	MAX	UNIT	REMARK
Lamp Voltage(IL=6.0mA)	VL	630	700	803	Vrms	IL=6.0mA
Lamp Current	IL	5.5	6.0	6.5	mArms	*1)
Inverter Frequency	FI	40	--	60	kHz	*2)
Lamp Initial Voltage	VS	1330	--		Vrms	Ta=25°C
		1650	--		Vrms	Ta=0°C

(b) LAMP LIFE – TIME

Lamp:

ITEM	IL at 2.0 mA	IL at 6.0 mA	IL at 6.5 mA	UNIT	REMARK
LAMP LIFE-TIME (LT)	Min. 15,000	Min. 15,000	Min.10,000	hr	Continuous Operation*3)
Turn-on and turn-off Operation	--	Min.100,000	--	times	Continuous Operation *4)

*1)Measure method : Galvanometer connect to low voltage

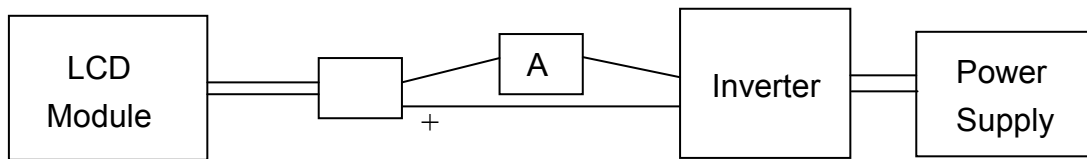

*2) Frequency in this range can make the characteristics of electric and optics maintain in +/- 10% except hue.

Lamp frequency of inverter may produce interference with horizontal synchronous frequency, and this may cause horizontal beat on the display. Therefore, please adjust lamp frequency, and keep inverter as far from module as possible or use electronic shielding between inverter and module to avoid the interference.

Under optimum operate frequency range (50~80 KHz), will not effect panel life-time and reliability .

CHUNGHWA PICTUER TUBES, LTD.

TECHNICAL SPECIFICATION

Doc. No : _____
 Version : V1
 Issue Date : 2007/06/26

Title : CLAA154WB08A Technical Specification

21	NC	VCOM test provided , but customer-end unused (open)
22	NC	No connect
23	NC	No connect
24	NC	No connect
25	NC	No connect
26	NC	No connect
27	NC	No connect
28	NC	No connect
29	NC	No connect
30	NC	No connect

(b) CN2 (BACKLIGHT)

Backlight-side connector: BHSR-02VS-1 (JST)

Inverter-side connector: SM02B-BHSS-1 (JST)

Pin No.	Symbol	Function
1	CTH	VBLH (High)
2	CTL	VBLL (Low)

[Note] : VBLH-VBLL=VL

[Note]

BIST (Build in self-test pattern)

BIST pin = low(GND) : Normal

BIST pin = high(VCC) : Self-test mode

1) Self-test Display Pattern change when pin 5 is high and no LVDS input signals detected, as followed patterns runs continuously. (Black, White, Red, Green and Blue).

2) Pattern sequence

Pattern1 → Pattern2 → Pattern3 → Pattern4 → Pattern5 → Pattern1 →

Title : CLAA154WB08A

Technical Specification

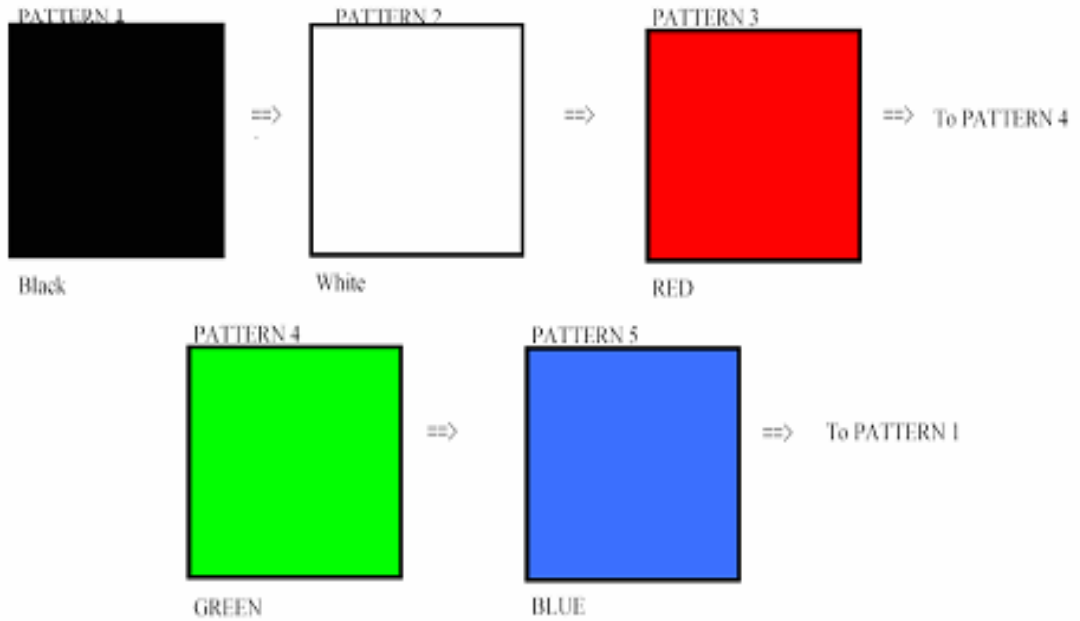

5. INTERFACE TIMING CHART

(a). LVDS input time sequence

Horizontal sequence

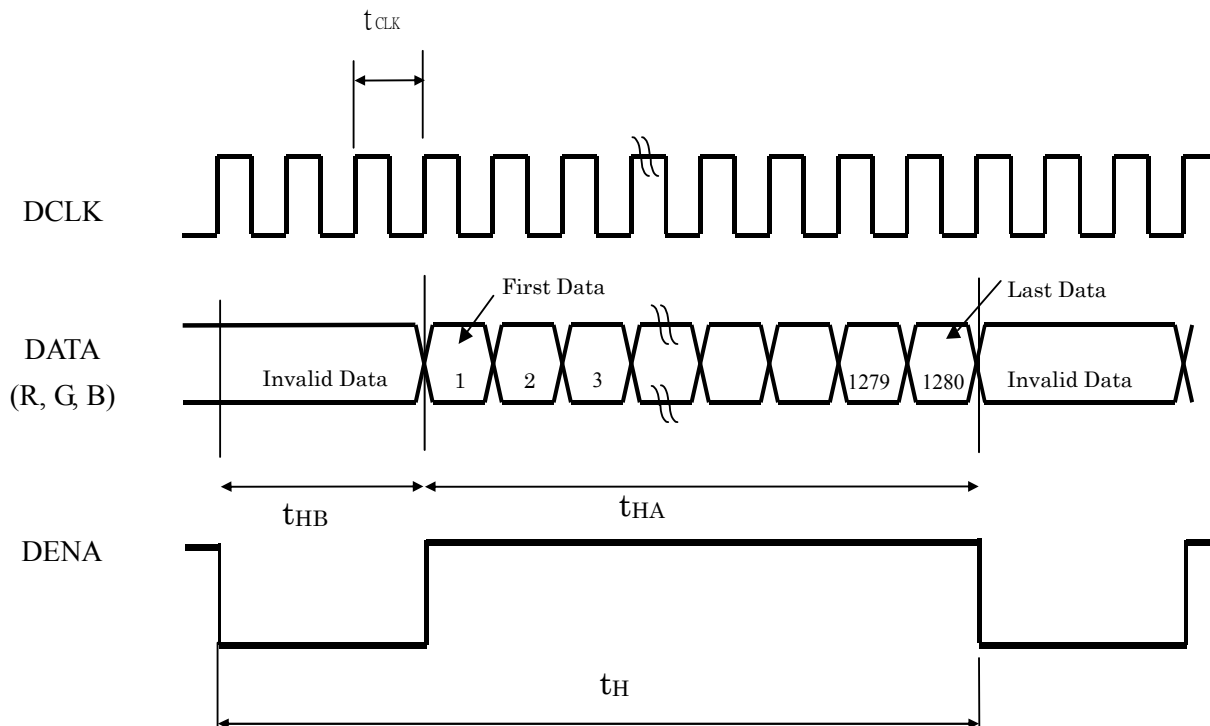

Title : CLAA154WB08A Technical Specification

(b) LCD input time sequence

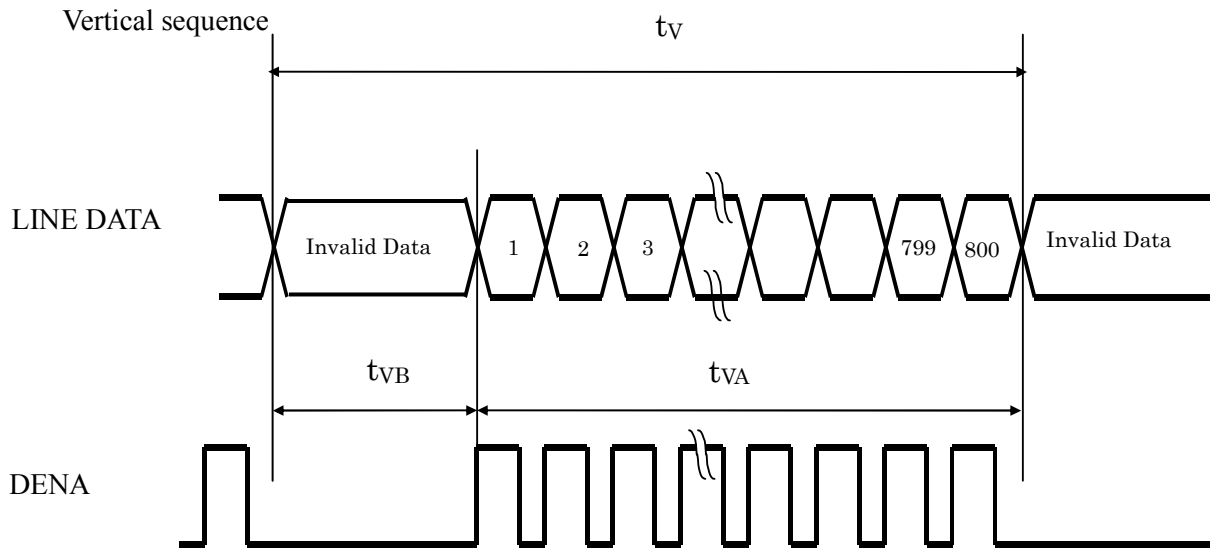

(2) Timing Chart

ITEM		SYMBOL	MIN	TYP	MAX	UNIT		
LCD Timing	DCLK	Frequency	f_{CLK}	65.3	71	74.7	MHz	
		Period	t_{CLK}	15.3	14.08	13.3	ns	
	DENA	Horizontal	Horizontal total time	t_H	1344	1424	1500	t_{CLK}
			Horizontal Active time	t_{HA}	1280	1280	1280	t_{CLK}
			Horizontal Blank time	t_{HB}	64	144	220	t_{CLK}
	DENA	Vertical	Vertical total time	t_V	810	816	830	t_H
			Vertical Active time	t_{VA}	800	800	800	t_H
			Vertical Blank time	t_{VB}	10	16	30	t_H

[Note]

- *1) Data is latched during DCLK falling period.
- *2) HD、VD is negative.
- *3) DENA (DATA ENABLE) usually is positive.
- *4) During the whole blank period, DCLK should keep input.
 During the vertical blank period, HD should keep input.

CHUNGHWA PICTUER TUBES, LTD.

TECHNICAL SPECIFICATION

Doc. No : _____
 Version : V1
 Issue Date : 2007/06/26

Title : CLAA154WB08A Technical Specification

(3) DATA mapping

Color	Input Data	R DATA						G DATA						B DATA					
		R5	R4	R3	R2	R1	R0	G5	G4	G3	G2	G1	G0	B5	B4	B3	B2	B1	B0
		MS B					LS B	MS B					LS B	MS B					LS B
Basic Color	Black	0	0	0	0	0	0	0	0	0	0	0	0	0	0	0	0	0	0
	Red(63)	1	1	1	1	1	1	0	0	0	0	0	0	0	0	0	0	0	0
	Green(63)	0	0	0	0	0	0	1	1	1	1	1	1	0	0	0	0	0	0
	Blue(63)	0	0	0	0	0	0	0	0	0	0	0	0	1	1	1	1	1	1
	Cyan	0	0	0	0	0	0	1	1	1	1	1	1	1	1	1	1	1	1
	Magenta	1	1	1	1	1	1	0	0	0	0	0	0	1	1	1	1	1	1
	Yellow	1	1	1	1	1	1	1	1	1	1	1	1	0	0	0	0	0	0
	White	1	1	1	1	1	1	1	1	1	1	1	1	1	1	1	1	1	1
RED	RED(0)	0	0	0	0	0	0	0	0	0	0	0	0	0	0	0	0	0	0
	RED(1)	0	0	0	0	0	1	0	0	0	0	0	0	0	0	0	0	0	0
	RED(2)	0	0	0	0	1	0	0	0	0	0	0	0	0	0	0	0	0	0
	RED(62)	1	1	1	1	1	0	0	0	0	0	0	0	0	0	0	0	0	0
	RED(63)	1	1	1	1	1	1	0	0	0	0	0	0	0	0	0	0	0	0
Green	Green(0)	0	0	0	0	0	0	0	0	0	0	0	0	0	0	0	0	0	0
	Green(1)	0	0	0	0	0	0	0	0	0	0	0	1	0	0	0	0	0	0
	Green(2)	0	0	0	0	0	0	0	0	0	0	1	0	0	0	0	0	0	0

CHUNGHWA PICTUER TUBES, LTD.

TECHNICAL SPECIFICATION

Doc. No : _____
 Version : V1
 Issue Date : 2007/06/26

Title : CLAA154WB08A Technical Specification

	Green(62)	0	0	0	0	0	0	1	1	1	1	1	0	0	0	0	0	0	0
	Green(63)	0	0	0	0	0	0	1	1	1	1	1	1	0	0	0	0	0	0
Blue	Blue(0)	0	0	0	0	0	0	0	0	0	0	0	0	0	0	0	0	0	0
	Blue(1)	0	0	0	0	0	0	0	0	0	0	0	0	0	0	0	0	0	1
	Blue(2)	0	0	0	0	0	0	0	0	0	0	0	0	0	0	0	0	1	0
	Blue(62)	0	0	0	0	0	0	0	0	0	0	0	0	1	1	1	1	1	0
	Blue(63)	0	0	0	0	0	0	0	0	0	0	0	0	1	1	1	1	1	1

[Note]

- 1) Gray level:
 Color(n) : n is level order; higher n means brighter level.
- 2) DATA:
 1: high , 0: low

6. BLOCK DIAGRAM

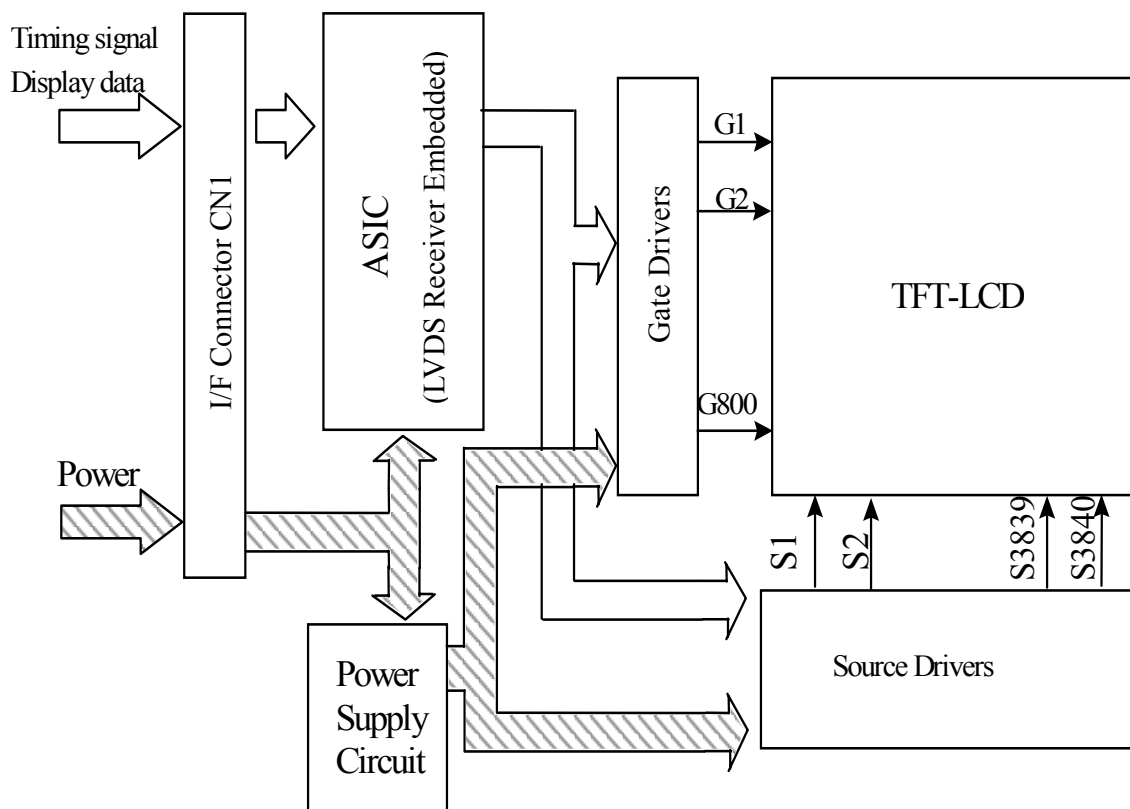

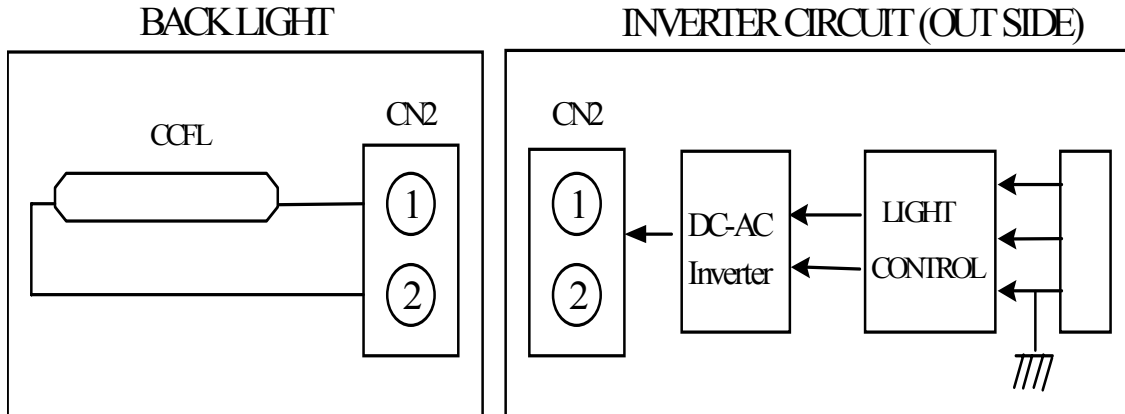

7. MECHANICAL SPECIFICATION

(1) Front side

The tolerance, not show in the figure, is $\pm 0.5\text{mm}$.

[Unit : mm]

Title : CLAA154WB08A Technical Specification

2) Rear side

The tolerance, not show in the figure, is $\pm 0.5\text{mm}$.

[Unit : mm]

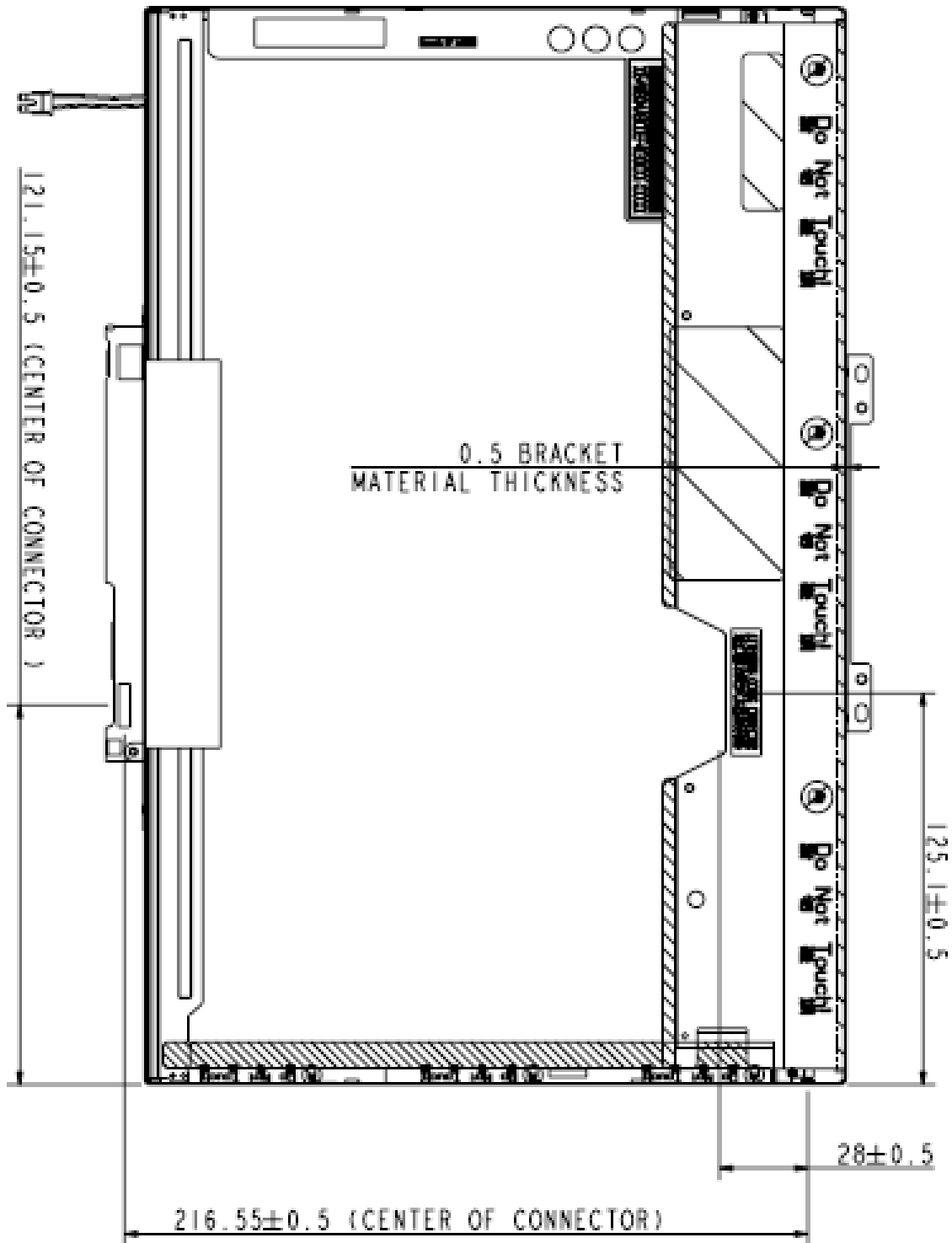

Title : CLAA154WB08A**Technical Specification****8. OPTICAL CHARACTERISTICS****Ta=25°C , VDD=3.3V**

ITEM	SYMBOL	CONDITION	MIN.	TYP.	MAX.	UNIT	REMARK	
Contrast Ratio	CR	$\theta = \psi = 0^\circ$	300	350		--	*1)	
Luminance (5P)	L	$\theta = \psi = 0^\circ$	200	220		cd/m ²	*2)	
Uniformity(5P)	ΔL	$\theta = \psi = 0^\circ$	80			%	*2)	
Uniformity(13P)	ΔL	$\theta = \psi = 0^\circ$	65			%		
Response Time	Tr	$\theta = \psi = 0^\circ$		6	9	ms	*4)	
	Tf	$\theta = \psi = 0^\circ$		10	16	ms	*4)	
Image sticking	Tis	16 hours		-	20	min	*5)	
Cross talk	CT	$\theta = \phi = 0^\circ$ ^{*3}			1	%	*6)	
View angle	Horizontal	ψ	CR \geq 10	40/-40	45/-45		°	*3)
	Vertical	θ		15/-30	20/-35		°	*3)
Color Temperature Coordinate	W	X	$\theta = \psi = 0^\circ$	0.293	0.313	0.333		*2)
		Y		0.309	0.329	0.349		
	R	X		0.585	0.605	0.625		
		Y		0.327	0.347	0.367		
	G	X		0.295	0.315	0.335		
		Y		0.561	0.581	0.601		
	B	X		0.133	0.153	0.173		
		Y		0.106	0.126	0.146		
Gamut		$\theta = \psi = 0^\circ$	45%	50%		%		
Gamma	γ	GL	2.0	2.2	2.4		*7)	

Color coordinate and color gamut are measured by CS-1000, and all the other items are measured by BM-5A (TOPCON). All these items are measured under the dark room condition (no ambient light).

Measurement Condition: IL = 6.5 mA (SMB_DATA=FFH)

Inverter : SUMIDA / IV12139/T

Definition of these measurement items is as follows:

***1) Definition of Contrast Ratio**

CR=ON (White) Luminance/OFF (Black) Luminance

Title : CLAA154WB08A Technical Specification

***2) Definition of Luminance and Luminance uniformity**

Central luminance: The white luminance is measured at the center position “5” on the screen, see Fig.1 below.

5P Luminance (AVG): The white luminance is measured at measuring points 5、10、11、12、13, see Fig. 1 below.

5P Uniformity: $\Delta L = (L_{min} / L_{max}) \times 100\%$

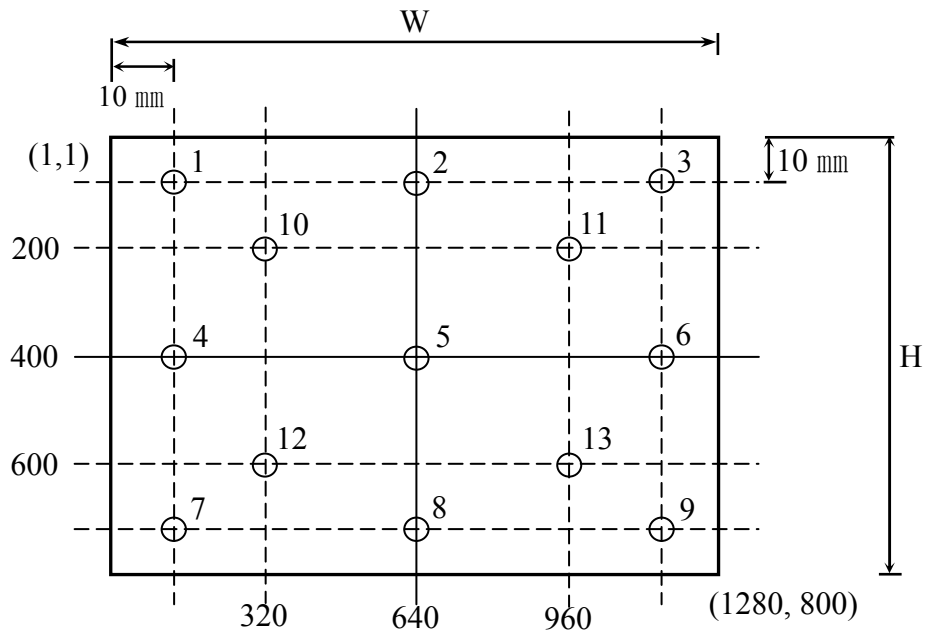
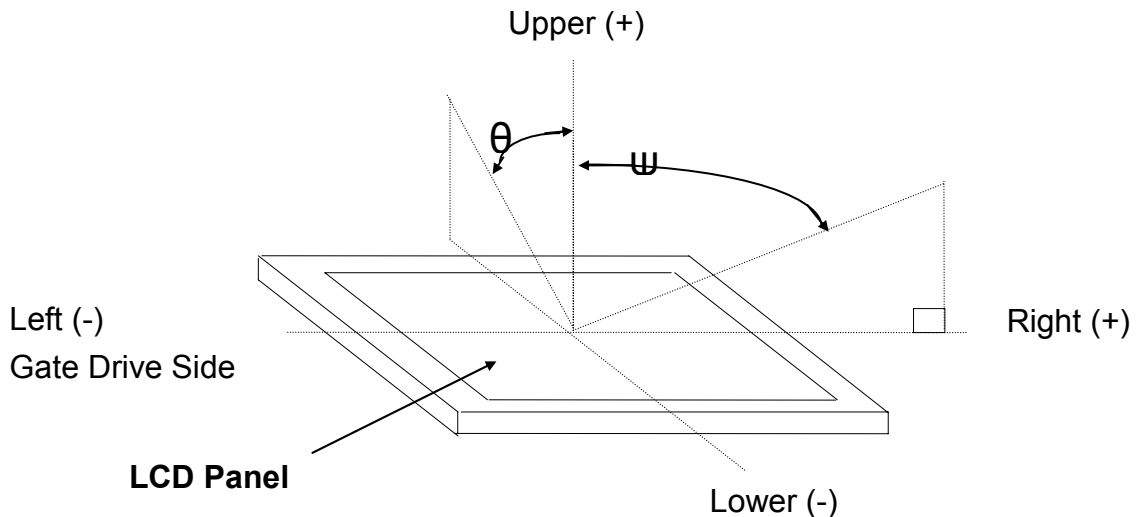

Fig.1 measuring points

***3) Definition of view angle(θ , ψ)**



Title : CLAA154WB08A Technical Specification

***4) Definition of response time**

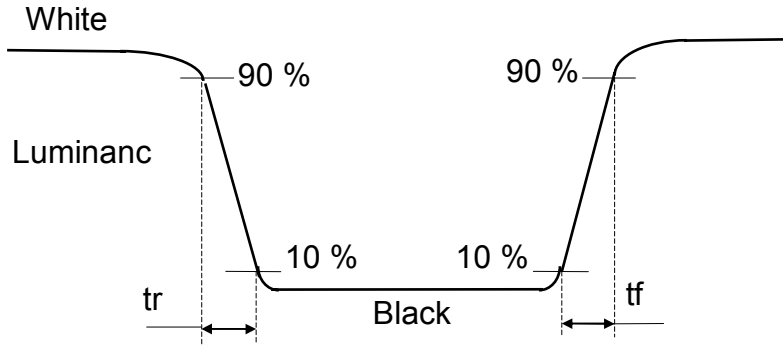

***5) Definition of image sticking**

Continuously display the test pattern shown in the figure below for 16 hrs. At 25°C.

To change the picture to gray pattern (gray 32 pattern), and the previous image shall not persist during 20 min .

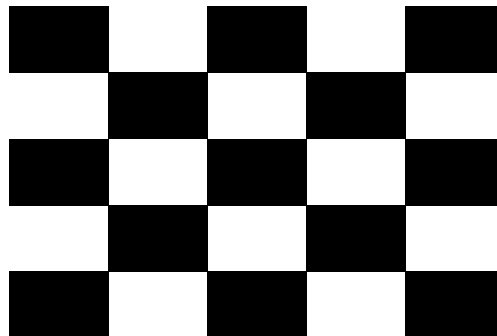

White : 63 Gray
 Black : 0 Gray

***6) Crosstalk Modulation Ratio:**

$$CT = | Y_B - Y_A | / Y_A \times 100\%$$

Y_A 、 Y_B measure position and definition

Y_A means luminance at gray level 32(exclude gray level 0 pattern)

Y_B means luminance at gray level 32(include gray level 0 pattern)

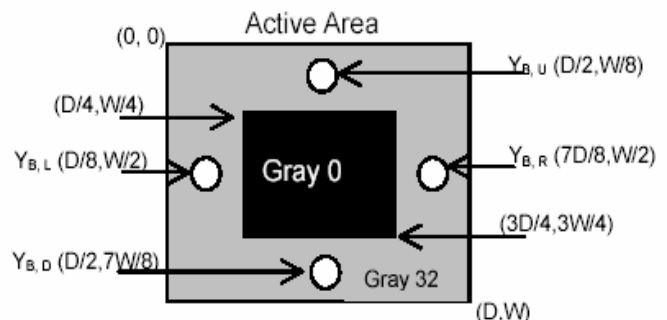
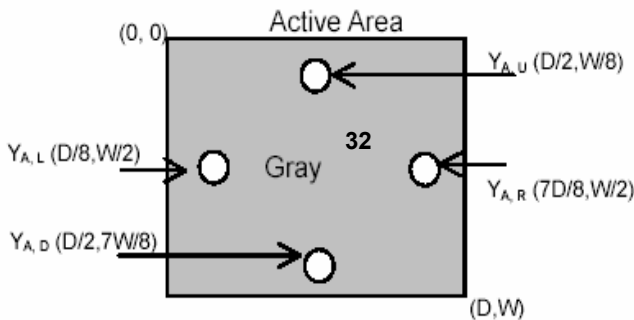

Title : CLAA154WB08A Technical Specification

***7) Definition Gamma (VESA)**

Based on Customer Sample, take the average value as a standard center value and the variation range of Gamma value caused by loop voltage error should be between +/- 0.2. the bellow figure shows how to obtain the gamma curve and γ (from gray level: 0、16、32----224、240、255).

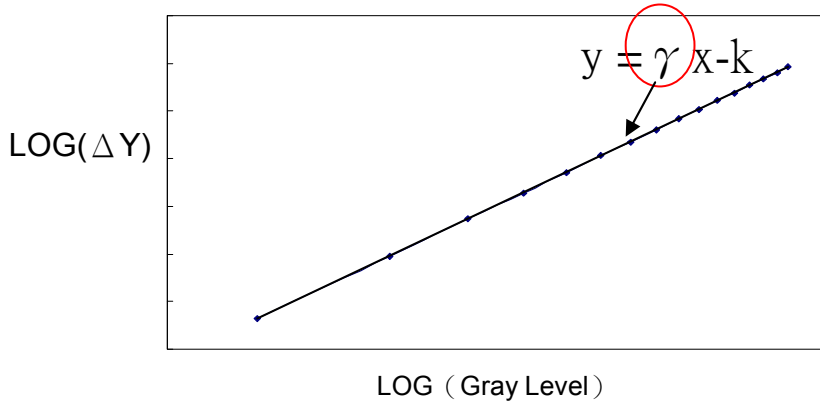

9. RELIABILITY TEST CONDITIONS

(1) Temperature、Humidity and Pressure

TEST ITEMS	CONDITIONS
High Temperature Operation	50° C ; 250Hrs
High Temperature Storage	65° C ; 250Hrs
High Temperature High Humidity Operation	40° C ; 95% RH ; 250Hrs
High Temperature High Humidity Storage	60° C ; 95% RH ; 48 Hrs
Low Temperature Operation	0° C ; 250 Hrs
Low Temperature Storage	-25° C ; 250 Hrs
Thermal Shock	-40° C (30 Mins)~65° C (30 Mins) , Ramp<20° C , 100 CYCLE
Temperature and Pressure Storage	25° C、260hPa、24hrs

(2) Shock & Vibration

TEST ITEMS	CONDITIONS
Shock (Non-Operation)	Shock level : 2450m/s ² (250G), Waveform : half sinusoidal wave, 2ms, 6 axis (± X,± Y,± Z) per cycle
Vibration (Non-Operation)	Vibration level : 14.7m/s ² (1.5G), sinusoidal wave (each x,y,z axis : 1hr, total 3hrs) Frequency range : 5~500 Hz Sweep speed : 0.5 Octave/min.

CHUNGHWA PICTUER TUBES, LTD.

TECHNICAL SPECIFICATION

Doc. No : _____
 Version : V1
 Issue Date : 2007/06/26

Title : CLAA154WB08A Technical Specification

(3) ESD

Power on or off	Power on		Power off		
Test Position	Surface discharge(Panel display area、Frame、PWB、Panel back side)		Electrics capacity of Connector	Surface discharge (Frame)	Surface discharge (Edge of panel)
Mode	Contact	Air	Contact	Contact	Air
Capacity	150 pF	150 pF	200 pF	150 pF	150 pF
Resistance	330 Ω	330 Ω	0 Ω	330 Ω	330 Ω
Voltage	±8kV/±15kV	±8kV/±15kV	±250 V	±6kV/±8kV	±8kV/±15kV
Interval	1 sec	1 sec	1 sec	1 sec	1 sec
Times(single point)	25	25	1	25	25

(4) MTBF without B/L: 200,000 Hrs (min) lifetimes.

(5) Judgment standard

The judgment of the above test should be made as follow:

Pass : Normal display image with no obvious non-uniformity and no line defect.

Partial transformation of the module parts should be ignored.

Fail : No display image, obvious non-uniformity, or line defects.