

Toshiba Mobile Display Co., Ltd.

33.8cm COLOUR TFT-LCD MODULE
(13.3 TYPE)
LT133EE10000
(p-Si TFT)

PRODUCT INFORMATION

All information is subject to change without notice. Please read bottom notes.

FEATURES

- (1) 13.3" HD(1366x768 pixels) display size for notebook PC
- (2) LED Backlight (with LED Driver)
- (3) Glare (Plane HC)
- (4) LVDS interface
- (5) EDID

TENTATIVE

MECHANICAL SPECIFICATIONS

Item	Specifications
Dimensional Outline (typ.)	307.6 (W) x 183.1 (H) x 5.2(D) Max. mm
Number of Pixels	1366 (W) x 768 (H) pixels
Active Area	293.42 (W) x 164.97 (H) mm
Pixel Pitch	0.2148 (W) x 0.2148 (H) mm
Weight (approximately)	350 g (Max)
Backlight	LED type, with LED Driver

ABSOLUTE MAXIMUM RATINGS

Item		Min.	Max.	Unit	Checked Terminal
Supply Voltage	V_{DD}	-0.3	+4.0	V	$V_{DD} - GND$
Input Voltage of Signals	V_{IN}	-0.3	$V_{DD}+0.3$	V	LVDS interface
LED Driver Supply Voltage	V_{LED}	6.0	21.0	V	
Operating Ambient Temperature	T_{OP}	0	+50	°C	
Operating Ambient Humidity	H_{OP}	10	90	%(RH)	
Storage Temperature	T_{STG}	-20	+60	°C	
Storage Humidity	H_{STG}	10	90	%(RH)	
Operating Temperature for Panel	-	0	+60	°C	

ELECTRICAL SPECIFICATION

Item		Min.	Typ.	Max.	Unit	Remarks
Supply Voltage	V_{DD}	3.0	3.3	3.6	V	
Common Mode Input Voltage	V_{CM}	1.15	-	1.45	V	
Differential Input amplitude	V_{ID}	0.1	-	0.6	V	
Supply LED Driver input Voltage	V_{LED}	7.0	-	20.0	V	

*1 : 8 color bars pattern is considered typical condition.

*2 : The current value of each row should be the same value.

OPTICAL SPECIFICATION ($T_a=25^\circ\text{C}$)

Item		Min.	Typ.	Max.	Unit	Remarks
Contrast Ratio	(CR)	300	600	---	---	
Response Time	(t_{ON})+ (t_{OFF})	---	16	---	ms	$t=25^\circ\text{C}$
Luminance (5point)	(L)	(140)	200	---	cd/m ²	PWM=100%
Duty ratio	(Duty)	5	---	100	%	PWM 200Hz - 1.1kHz(max)

*The information contained herein is presented only as a guide for the applications of our products. No responsibility is assumed by Toshiba Mobile Display or other rights of the third parties which may result from its use. No license is granted by implication or otherwise under any patent or patent rights of Toshiba Mobile Display or others.

*The information contained herein may be changed without prior notice. It is therefore advisable to contact Toshiba Mobile Display before proceeding with the design of equipment incorporating this product.

DIMENSIONAL OUTLINE
(Front side)

TENTATIVE

Unit : mm

Standard tolerance : ± 0.5

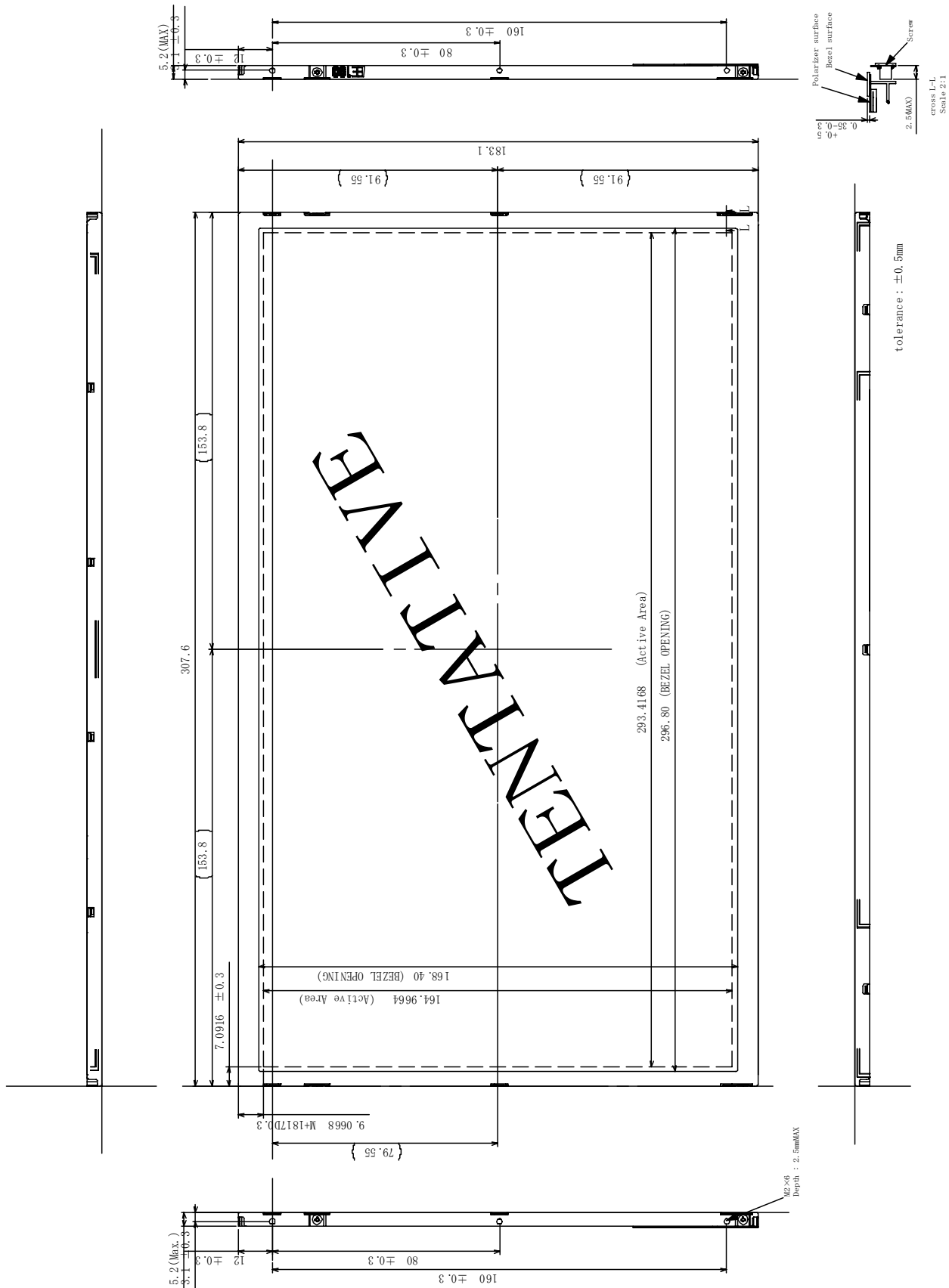

TENTATIVE

DIMENSIONAL OUTLINE
(Back side)

TENTATIVE

Unit : mm

Standard tolerance : ± 0.5

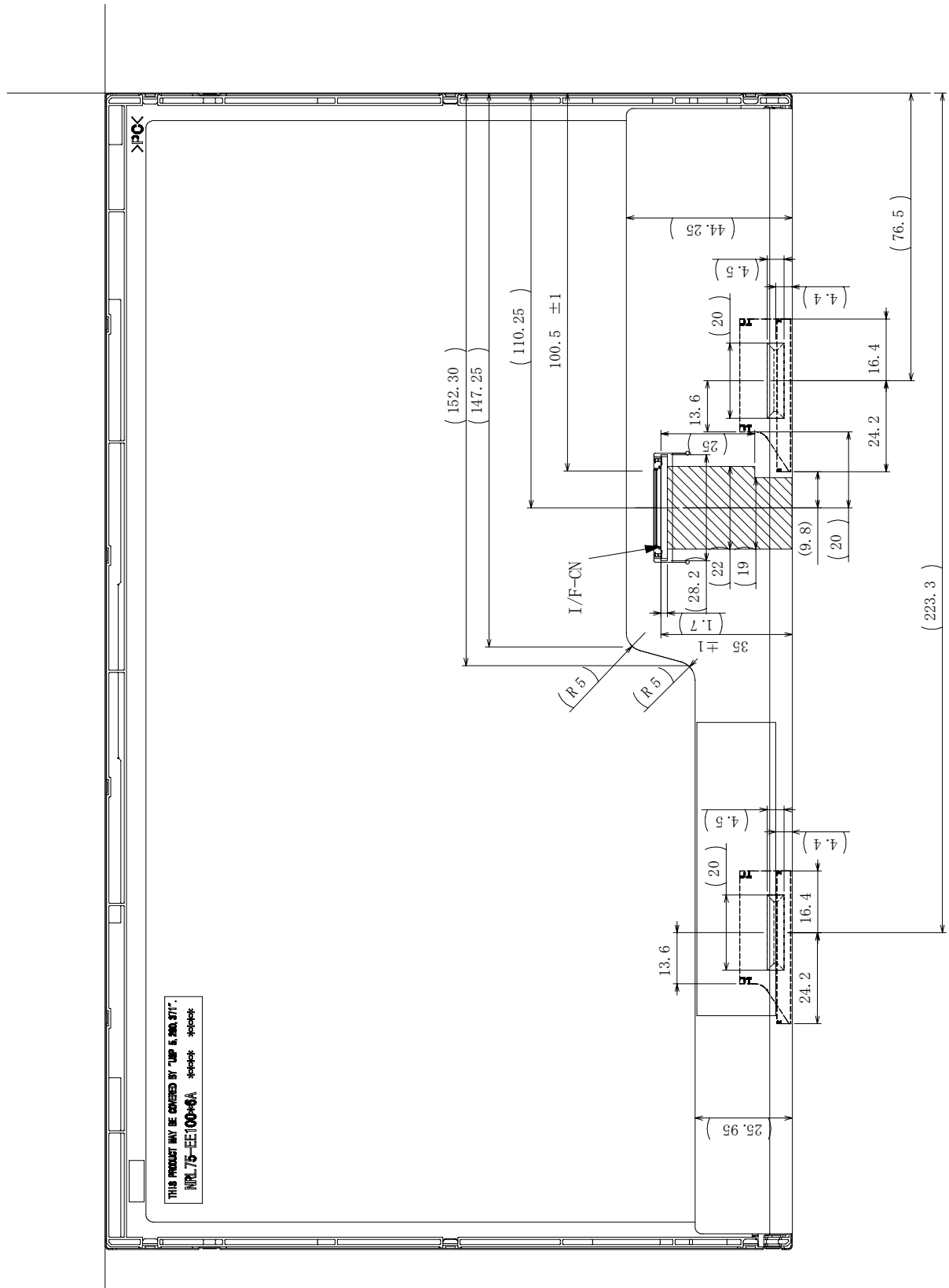

BLOCK DIAGRAM

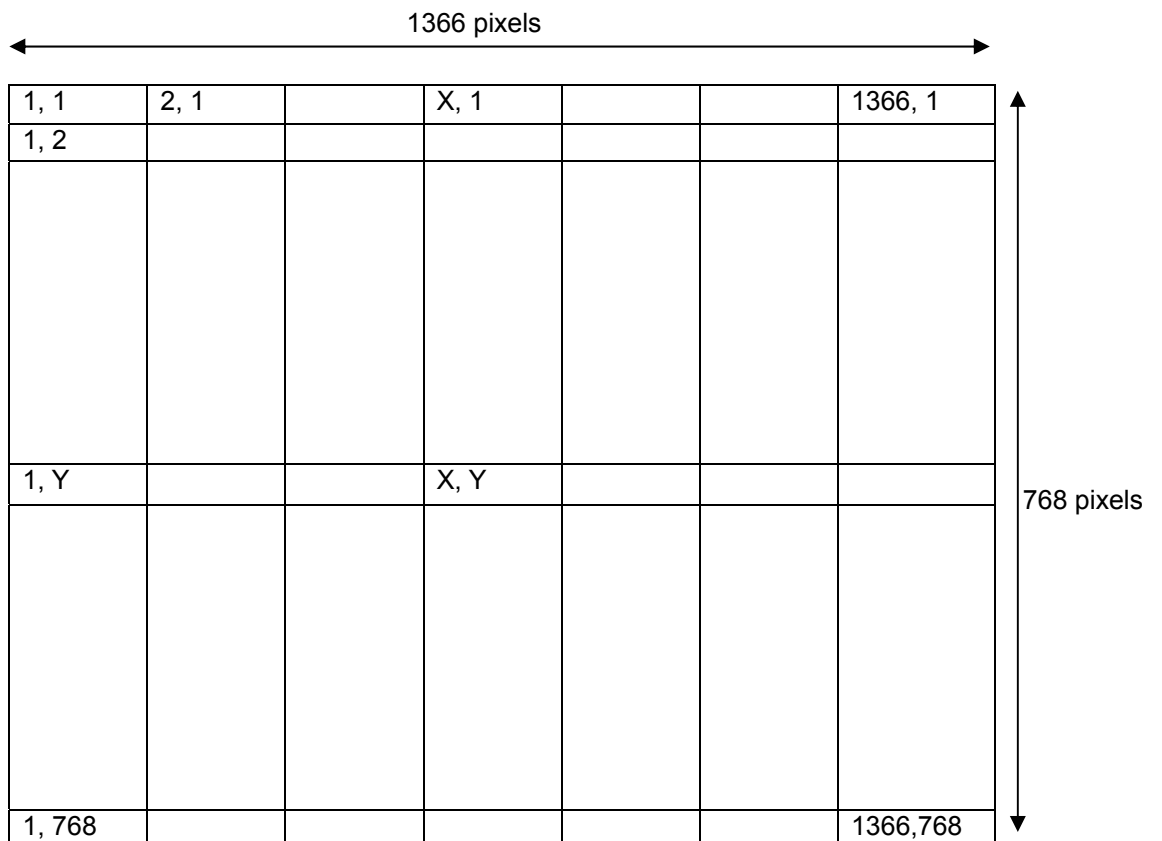
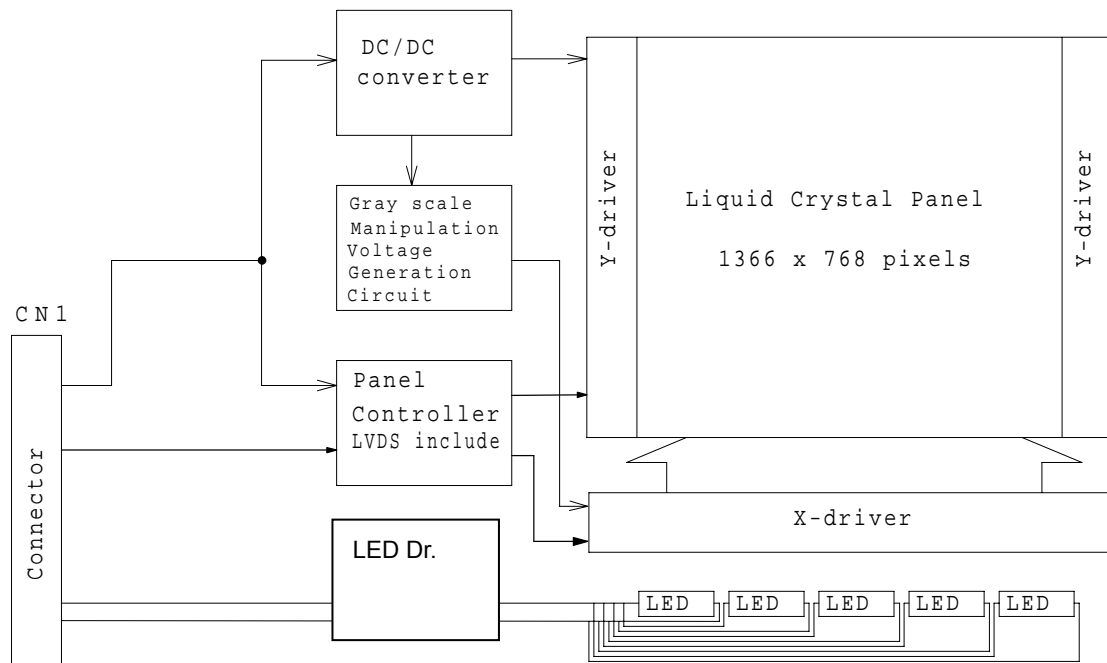

TIMING CHART

(1) Vertical Timing

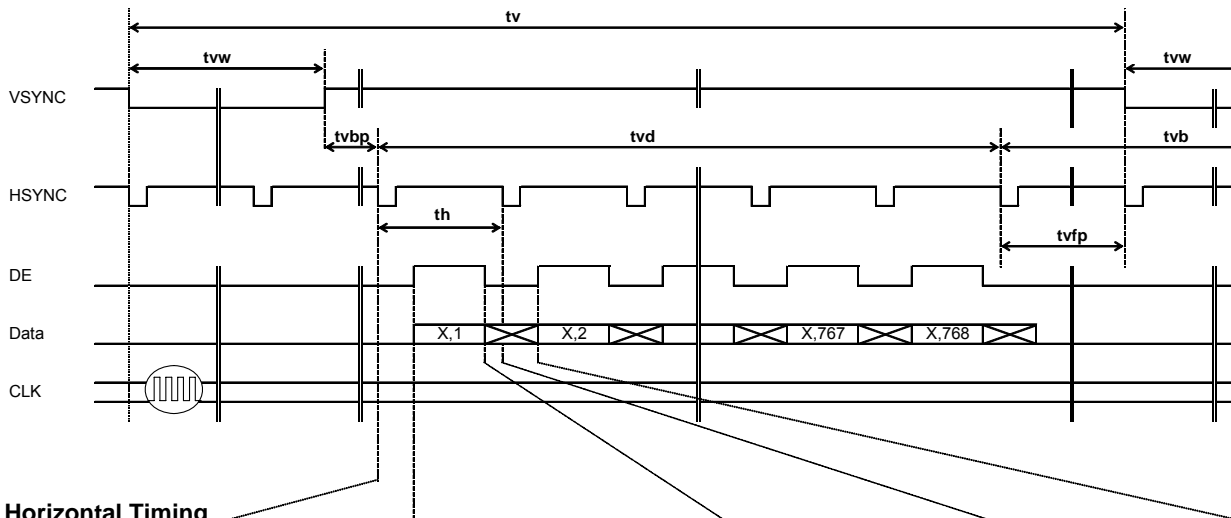

(2) Horizontal Timing

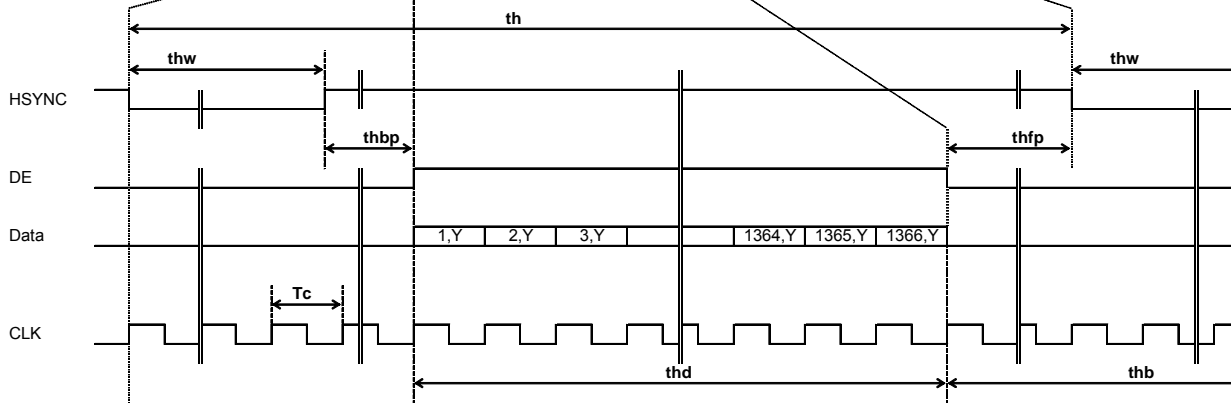

POWER SEQUENCE

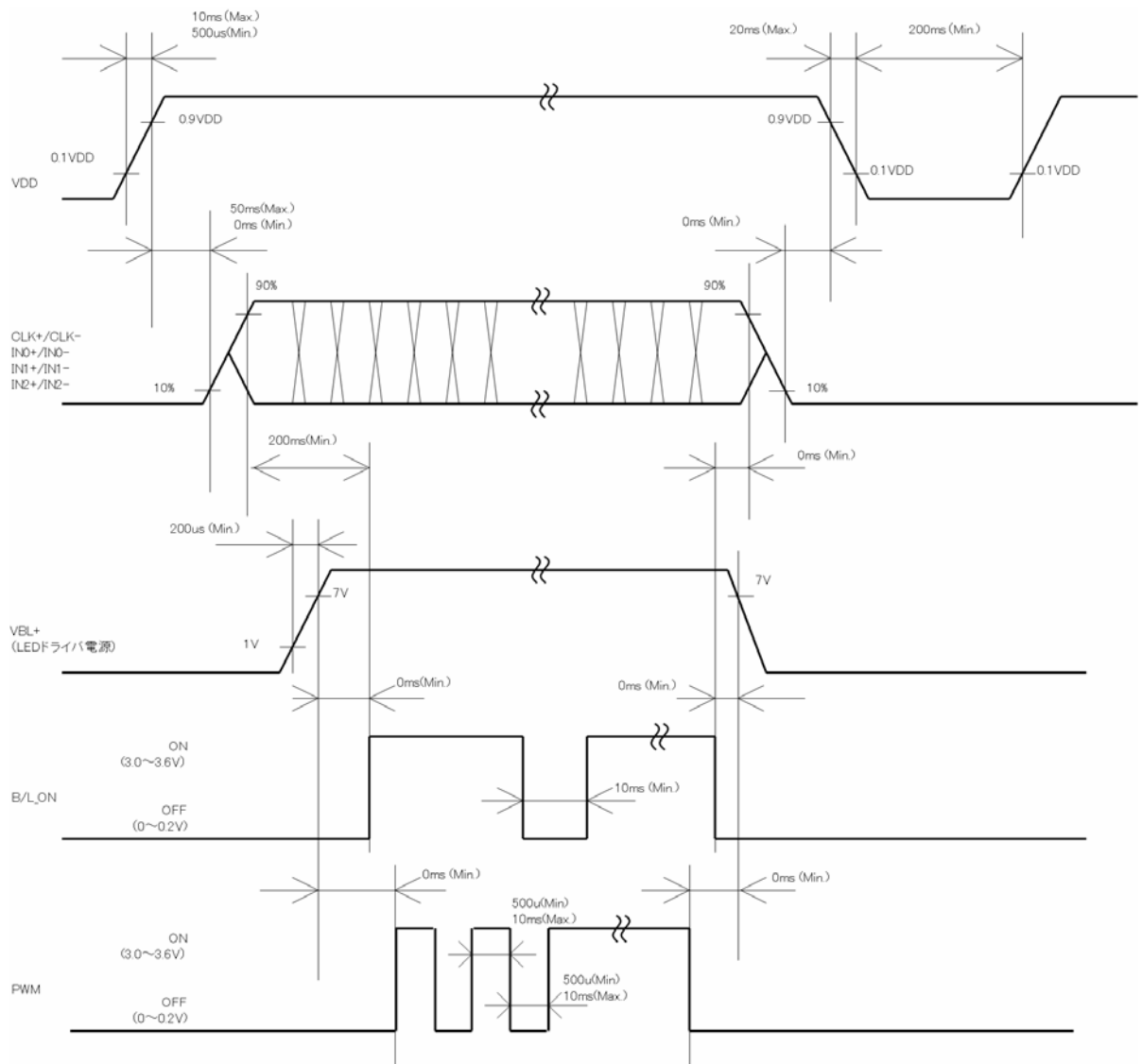

TIMING SPECIFICATION ^{1) 2) 3) 4) 5) 6)}

Item	Symbol	min.	typ.	max.	Unit
Frame Period	<i>T_v</i>	773	773	773	th
		16.67	16.67	-	ms
Vertical Display Term	<i>T_{vd}</i>	768	768	768	th
Vertical Blanking Period	<i>T_{vb}</i>	5	5	5	th
Horizontal Scanning Term	<i>T_h</i>	1518	1641	1790	tc
		21.56	21.56	21.56	μs
Horizontal Display Term	<i>T_{hd}</i>	1366	1366	1366	tc
Horizontal Blanking Period	<i>T_{hb}</i>	152	275	424	tc
Clock Period	<i>T_c</i>	70.4	76.11	83	MHz
		14.20	13.14	12.05	ns
V-sync Pulse Width	<i>T_{vw}</i>	1	2	-	th
Vertical Front Porch	<i>T_{vfp}</i>	1	1	-	th
Vertical Back Porch	<i>T_{vbp}</i>	2	2	-	th
H-sync Pulse Width	<i>T_{hw}</i>	4	112	-	tc
Horizontal Front Porch	<i>T_{hfp}</i>	4	35	-	tc
Horizontal Back Porch	<i>t_{hbp}</i>	4	128	-	tc
DE Pulse Width	<i>T_{hd}</i>	1366	1366	1366	tc

Note 1) Refer to "Timing Chart" and LVDS (THC63LVDF84A-85) specifications by THine Electronics, Inc.

Note 2) If DE is fixed to "H" or "L" level for certain period while NCLK is supplied, the panel displays black with some flicker.

Note 3) If NCLK is fixed to "H" or "L" level for certain period while DE is supplied, the panel may be damaged.

Note 4) In case of using the long frame period, the deterioration of display quality, noise etc. may be occurred.

Note 5) NCLK count of each Horizontal Scanning Time should be always the same.

V-Blanking period should be "*n*" X "Horizontal Scanning Time". (*n*: integer)

Frame period should be always the same.

Note 6) Please keep below equations.

$$t_{vb} = t_{vw} + t_{vfp} + t_{vbp}$$

$$t_{hb} = t_{hw} + t_{hfp} + t_{hbp}$$

Note 7) The above tables shows allowable interface timings under 60Hz refresh rate conditions.

In case of using this rate condition, some flicker may be occurred.

CONNECTOR PIN ASSIGNMENT FOR INTERFACECN1 INPUT SIGNAL

CN1 INPUT SIGNAL (20455-040E-12 / I-PEX)

[Mating Connector :Wire Type 20453-040T-## / I-PEX / I-PEX]

Terminal No.	Symbol	Function
1	NC	Non-Connection
2	V _{DD}	Power Supply : +3.3V
3	V _{DD}	Power Supply : +3.3V
4	V _{EDID}	DDC 3.3V POWER SUPPLY : +3.3V
5	NC	Non-Connection
6	CLK _{EDID}	DDC Clock
7	DATA _{EDID}	DDC Data
8	RxIN0-	Negative LVDS differential data input (R0-R5,G0)
9	RxIN0+	Positive LVDS differential data input (R0-R5,G0)
10	V _{SS}	GND
11	RxIN1-	Negative LVDS differential data input (G1-G5, B0-B1)
12	RxIN1+	Positive LVDS differential data input (G1-G5, B0-B1)
13	V _{SS}	GND
14	RxIN2-	Negative LVDS differential data input (B2-B5, HS, VS, DE)
15	RxIN2+	Positive LVDS differential data input (B2-B5, HS, VS, DE)
16	V _{SS}	GND
17	CLK-	Clock Signal(-)
18	CLK+	Clock Signal(+)
19	V _{SS}	GND
20	NC	Non-Connection
21	NC	Non-Connection
22	NC	Non-Connection
23	NC	Non-Connection
24	NC	Non-Connection
25	NC	Non-Connection
26	NC	Non-Connection
27	NC	Non-Connection
28	NC	Non-Connection
29	NC	Non-Connection
30	NC	Non-Connection
31	VLED GND	LED Ground
32	VLED GND	LED Ground
33	VLED GND	LED Ground
34	NC	Non-Connection
35	PWM	PWM for Luminance control
36	BL ON	Backlight On/Off control
37	NC	Non-Connection
38	VLED	LED Power Supply (7-20V)
39	VLED	LED Power Supply (7-20V)
40	VLED	LED Power Supply (7-20V)

Note 1) Please connect GND pin to ground. Don't use it as no-connect nor connection with high impedance.

Note 2) Please connect NC to nothing. Don't connect it to ground nor to other signal input.

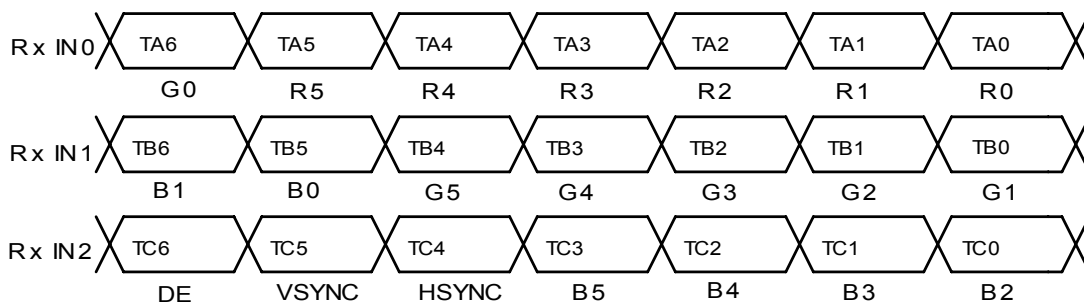

256k (k=1024) COLORS COMBINATION TABLE

	Display	R5 R4 R3 R2 R1 R0	G5 G4 G3 G2 G1 G0	B5 B4 B3 B2 B1 B0	Gray Scale Level
Basic Color	Black	L L L L L L	L L L L L L	L L L L L L	-
	Blue	L L L L L L	L L L L L L	H H H H H H	-
	Green	L L L L L L	H H H H H H	L L L L L L	-
	Light Blue	L L L L L L	H H H H H H	H H H H H H	-
	Red	H H H H H H	L L L L L L	L L L L L L	-
	Purple	H H H H H H	L L L L L L	H H H H H H	-
	Yellow	H H H H H H	H H H H H H	L L L L L L	-
Gray Scale of Red	White	H H H H H H	H H H H H H	H H H H H H	-
	Black	L L L L L L	L L L L L L	L L L L L L	L 0
	Dark ↑ ↓ Light	L L L L L H	L L L L L L	L L L L L L	L 1
		L L L L H L	L L L L L L	L L L L L L	L 2
		: : :	: : :	: : :	L3... L60
	Light	H H H H L H	L L L L L L	L L L L L L	L61
		H H H H H L	L L L L L L	L L L L L L	L62
Red	H H H H H H	L L L L L L	L L L L L L	Red L63	
Gray Scale of Green	Black	L L L L L L	L L L L L L	L L L L L L	L 0
	Dark ↑ ↓ Light	L L L L L L	L L L L L H	L L L L L L	L 1
		L L L L L L	L L L L H L	L L L L L L	L 2
		: : :	: : :	: : :	L3... L60
	Light	L L L L L L	H H H H L H	L L L L L L	L61
		L L L L L L	H H H H H L	L L L L L L	L62
	Green	L L L L L L	H H H H H H	L L L L L L	Green L63
Gray Scale of Blue	Black	L L L L L L	L L L L L L	L L L L L L	L 0
	Dark ↑ ↓ Light	L L L L L L	L L L L L H	L L L L L H	L 1
		L L L L L L	L L L L L L	L L L L H L	L 2
		: : :	: : :	: : :	L3... L60
	Light	L L L L L L	L L L L L L	H H H H L H	L61
		L L L L L L	L L L L L L	H H H H H L	L62
	Blue	L L L L L L	L L L L L L	H H H H H H	Blue L63
Gray Scale of White & Black	Black	L L L L L L	L L L L L L	L L L L L L	L 0
	Dark ↑ ↓ Light	L L L L L H	L L L L L H	L L L L L H	L 1
		L L L L H L	L L L L H L	L L L L H L	L 2
		: : :	: : :	: : :	L3... L60
	Light	H H H H L H	H H H H L H	H H H H L H	L61
		H H H H H L	H H H H H L	H H H H H L	L62
	White	H H H H H H	H H H H H H	H H H H H H	White L63



FOR SAFETY

LCD module is generally designed with precise parts to achieve light weighted thin mechanical dimensions. In using our Modules, make certain that you fully understand and put into practice the warnings and safety precautions detailed in Engineering Information No.EE-D-001A,"CAUTIONS AND INSTRUCTIONS FOR TOSHIBA MOBILE DISPLAY CO., LTD. LCD MODULES". Refer to individual specifications and TECHNICAL DATA sheets (hereinafter called "TD") for more detailed technical information.

1) SPECIAL PURPOSES

A) Toshiba Mobile Display's Standard LCD Modules have not been customized for operation in extreme environments or for use in applications where performance failures could be life-threatening or otherwise catastrophic.

B) Since Toshiba Mobile Display's Standard LCD Modules have not been designed for operation in extreme environments, they must never be used in devices that will be exposed to abnormally high levels of vibration or shock which exceed Toshiba Mobile Display's published specification limits.

C) In addition, since Toshiba Mobile Display Standard LCD Modules have not been designed for use in applications where performance failures could be life-threatening or catastrophic, they must never be installed in aircraft navigation control systems (such as, but not limited to Traffic Collision Avoidance System and Air Traffic Indicator), in military defense or weapons systems, in critical industrial process-control systems (e.g., those involved in the production of nuclear energy), or in critical medical device or patient life-support systems.

2) DISASSEMBLING OR MODIFICATION

DO NOT DISASSEMBLE OR MODIFY the module. It may damage sensitive parts inside LCD module, and may cause scratches or dust on the display.

Toshiba Mobile Display does not warrant the module, if customer disassembled or modified it.

3) BREAKAGE OF LCD PANEL

DO NOT INGEST liquid crystal material, DO NOT INHALE this material, and DO NOT CONTACT the material with skin, if LCD panel is broken and liquid crystal material spills out.

If liquid crystal material comes into mouth or eyes, rinse mouth or eyes out with water immediately.

If this material contact with skin or cloths, wash it off immediately with alcohol and rinse thoroughly with water.

4) GLASS OF LCD PANEL

BE CAREFUL WITH CHIPS OF GLASS that may cause injuring fingers or skin, when the glass is broken.

5) ELECTRIC SHOCK

DISCONNECT POWER SUPPLY before handling LCD module.

DO NOT TOUCH the parts inside LCD module and the connector or cables in order to prevent electric shock, because high voltage is supplied to these parts from power supply is turned on.

6) ABSOLUTE MAXIMUM RATINGS AND POWER PROTECTION CIRCUIT

DO NOT EXCEED the absolute maximum rating values under the worst probable conditions caused by the supply voltage variation, input voltage variation, variation in parts' constants, environmental temperature, etc., otherwise LCD module may be damaged.

Employ protection circuit for power supply, whenever the specification or TD specifies it.

Suitable protection circuit should be applied for each system design.

7) DISPOSAL

When dispose LCD module, obey to the applicable environmental regulations.