



HannStar Display Corp.

Document Title	HSD121PHW1-A Tentative Specification	Page No.	1/29
Document No.	DC110-000580	Revision	1.0

TO :

Date : Mar., 17, 2009

HannStar Product Specification **(Tentative)**

Model: HSD121PHW1
-A**

- Note: (1) The information contained herein is tentative and may be changed without prior notices
- (2) Please contact HannStar Display Corp. before designing your product based on this module specification.
- (3) The information contained herein is presented merely to indicate the characteristics and performance of our products. No responsibility is assumed by HannStar for any intellectual property claims or other problems that may result from application based on the module described herein.
- (4) The mark " ** " of Model means sub-model code.



HannStar Display Corp.

Document Title	HSD121PHW1-A Tentative Specification	Page No.	2/29
Document No.	DC110-000580	Revision	1.0

Record of Revisions

Rev.	Date	Sub-Model	Description of change
1.0	Mar, 17, 2008	A00	Tentative Product Specification was first released.



HannStar Display Corp.

Document Title	HSD121PHW1-A Tentative Specification	Page No.	3/29
Document No.	DC110-000580	Revision	1.0

Contents

1.0	General description	p.4
2.0	Absolute maximum ratings.....	p.5
3.0	Optical characteristics.....	p.6
4.0	Block diagram	p.10
5.0	Interface pin connection	p.12
6.0	Electrical characteristics	p.14
7.0	Reliability test items	p.21
8.0	Outline dimension	p.22
9.0	Lot mark	p.24
10.0	Package specification	p.25
11.0	General precaution	p.26



Document Title	HSD121PHW1-A Tentative Specification	Page No.	4/29
Document No.	DC110-000580	Revision	1.0

1.0 GENERAL DESCRIPTION

1.1 Introduction

HannStar Display model HSD121PHW1-A is a color active matrix thin film transistor (TFT) liquid crystal display (LCD) that uses amorphous silicon TFT as a switching device. This model is composed of a TFT LCD panel, a driving circuit and a back light system. This TFT LCD has a 16 (16:9) inch diagonally measured active display area with HD (1366 horizontal by 768 vertical pixel) resolution.

1.2 Features

- 12.1 (16:9 diagonal) inch configuration
- One channel LVDS interface
- 262K color by 6 bit R.G.B signal input
- RoHS Compliance
- Halogen Free

1.3 Applications

- NB

1.4 General information

Item	Specification	Unit	
Outline Dimension	279(Typ) x 167.2(Typ) x 5.1 (Max.)	mm	
Display area	268.01(H) x 150.68(V)	mm	
Number of Pixel	1366 RGB (H) x 768(V)	pixels	
Pixel pitch	0.1962(H) x 0.1962(V)	mm	
Pixel arrangement	RGB Vertical stripe		
Display mode	Normally white		
NTSC	50	%	
Surface treatment	Glare, Hard-Coating (3H)		
Weight	(250) (Typ.)	g	
Back-light	White LED		
Power Consumption	Logic System	(TBD) (Max.)	W
	B/L System	(TBD) (Max.)	W



Document Title	HSD121PHW1-A Tentative Specification	Page No.	5/29
Document No.	DC110-000580	Revision	1.0

1.5 Mechanical Information

Item		Min.	Typ.	Max.	Unit
Module Size	Horizontal (H)	278.5	279	279.5	mm
	Vertical (V)	166.7	167.2	167.7	mm
	Depth (D)	-	(4.8)	(5.1)	mm
Weight		-	(250)	(265)	g

2.0 ABSOLUTE MAXIMUM RATINGS

2.1 Electrical Absolute Rating

2.1.1 TFT LCD Module

Item	Symbol	Min.	Max.	Unit	Note
Logic Supply voltage	V_{DD}	-0.3	6.0	V	

2.1.2 Environment Absolute Rating

Item	Symbol	Min.	Max.	Unit	Note
Operating Temperature	T_{opa}	0	50		
Storage Temperature	T_{stg}	-20	60		



Document Title	HSD121PHW1-A Tentative Specification	Page No.	6/29
Document No.	DC110-000580	Revision	1.0

3.0 OPTICAL CHARACTERISTICS

3.1 Optical specification

Item		Symbol	Condition	Min.	Typ.	Max.	Unit	Note
Contrast		CR	=0 Normal viewing angle	-	(500)	-		(1)(2)(4)
Response time		RT		-	(12)	-	msec	(1)(3)
White luminance (5 point)		Y_L		-	(200)	-	cd/m ²	(1)(4)(5) ($I_L=20mA$)
Color chromaticity (CIE1931)	Red	R_x		-	(TBD)	-		
		R_y		-	(TBD)	-		
	Green	G_x		-	(TBD)	-		
		G_y		-	(TBD)	-		
	Blue	B_x		-	(TBD)	-		
		B_y		-	(TBD)	-		
	White	W_x		0.283	0.313	0.343		
		W_y	0.299	0.329	0.359			
Viewing angle	Hor.	L	-	45	-		(1)(4)	
		R	-	45	-			
	Ver.	U	-	15	-			
		D	-	35	-			
Brightness uniformity		B_{UNI}	=0 (5point)	80	-	-	%	(6)
Brightness Uniformity		B_{UNI}	=0 (13 points)	70	-	-	%	(6)

3.2 Measuring Condition

- Measuring surrounding : dark room
- Ambient temperature : 25±2°C
- 15min. warm-up time.



Document Title	HSD121PHW1-A Tentative Specification	Page No.	7/29
Document No.	DC110-000580	Revision	1.0

3.3 Measuring Equipment

- FPM520 of Westar Display technologies, INC., which utilized SR-3 for Chromaticity and BM-5A for other optical characteristics.
- Measuring spot size : 20 ~ 21 mm

Note (1) Definition of Viewing Angle:

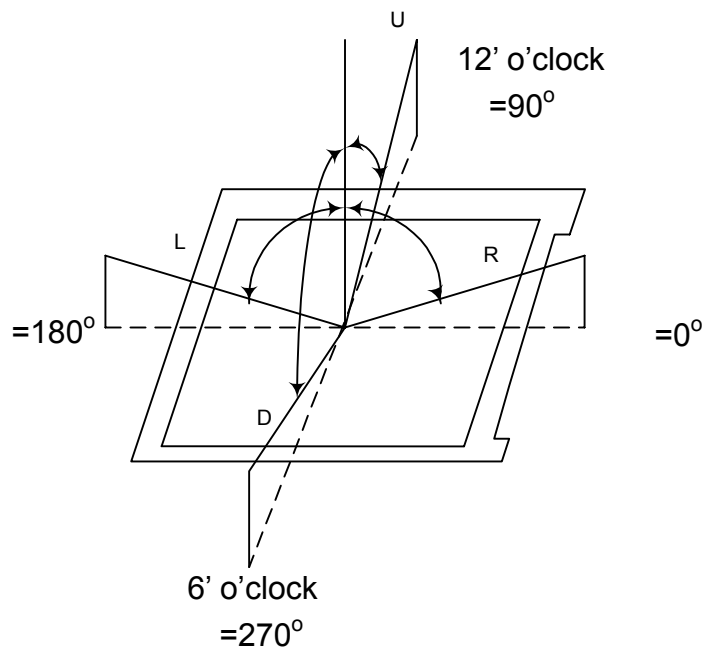

Note (2) Definition of Contrast Ratio (CR) :
measured at the center point of panel

$$CR = \frac{\text{Luminance with all pixels white}}{\text{Luminance with all pixels black}}$$



HannStar Display Corp.

Document Title	HSD121PHW1-A Tentative Specification	Page No.	8/29
Document No.	DC110-000580	Revision	1.0

Note (3) Definition of Response Time : Sum of T_R and T_F

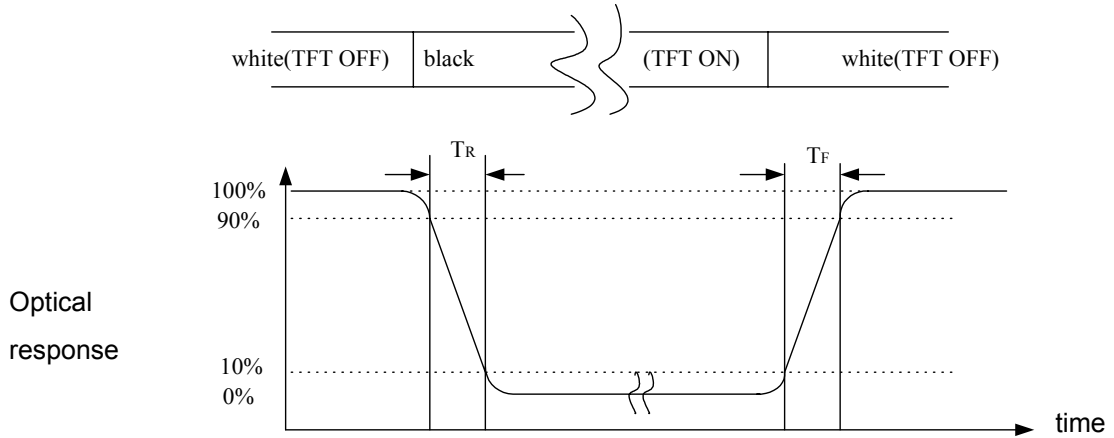

Note (4) Definition of optical measurement setup

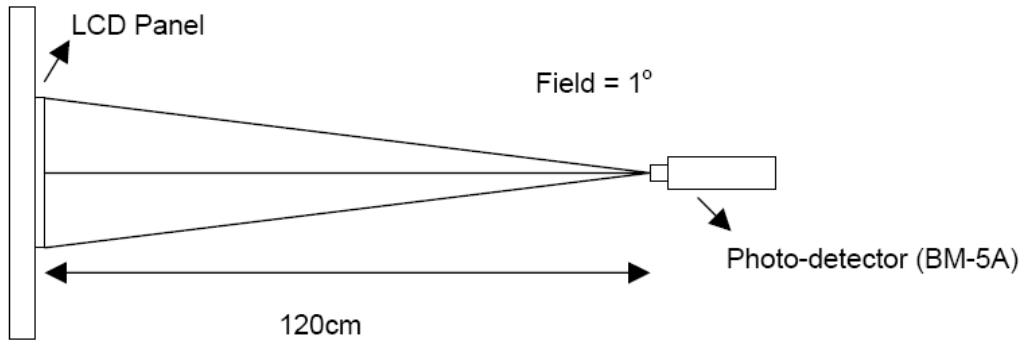



Document Title	HSD121PHW1-A Tentative Specification	Page No.	9/29
Document No.	DC110-000580	Revision	1.0

Note (5) Definition of Average Luminance Uniformity of White (5 Point)

$$\text{Average Luminance Uniformity} = \frac{Y_1+Y_2+Y_3+Y_4+Y_5}{5}$$

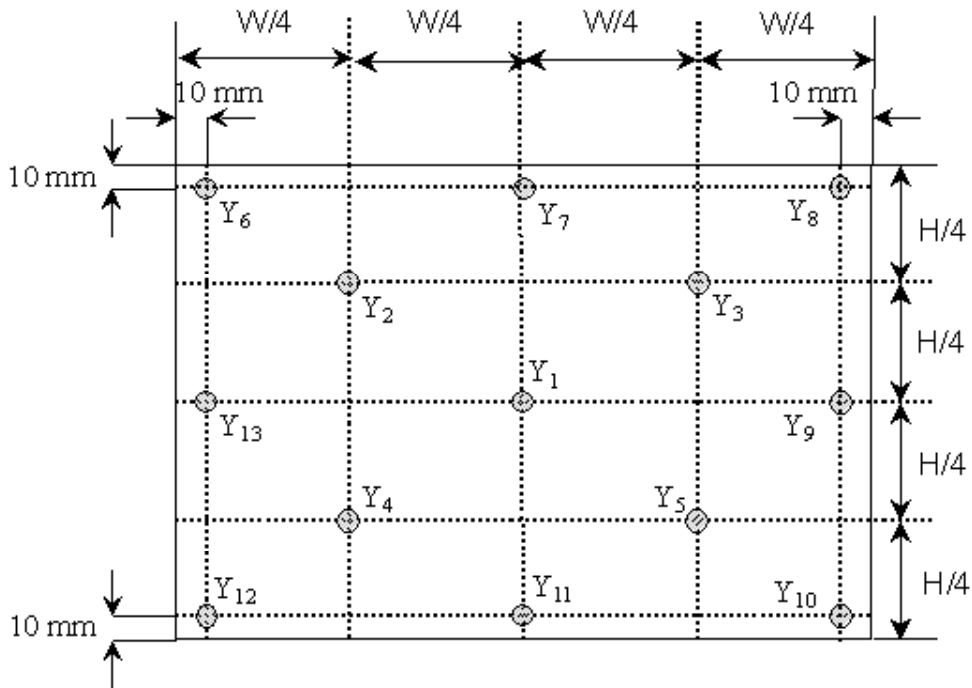

Note (6) Definition of brightness uniformity

$$\text{Luminance uniformity(5 points)} = \frac{(\text{Min Luminance of 5 points})}{(\text{Max Luminance of 5 points})} \times 100\%$$

$$\text{Luminance uniformity(13points)} = \frac{(\text{Min Luminance of 13 points})}{(\text{Max Luminance of 13 points})} \times 100\%$$



Document Title	HSD121PHW1-A Tentative Specification	Page No.	10/29
Document No.	DC110-000580	Revision	1.0

4.0 BLOCK DIAGRAM

4.1 TFT LCD Module:

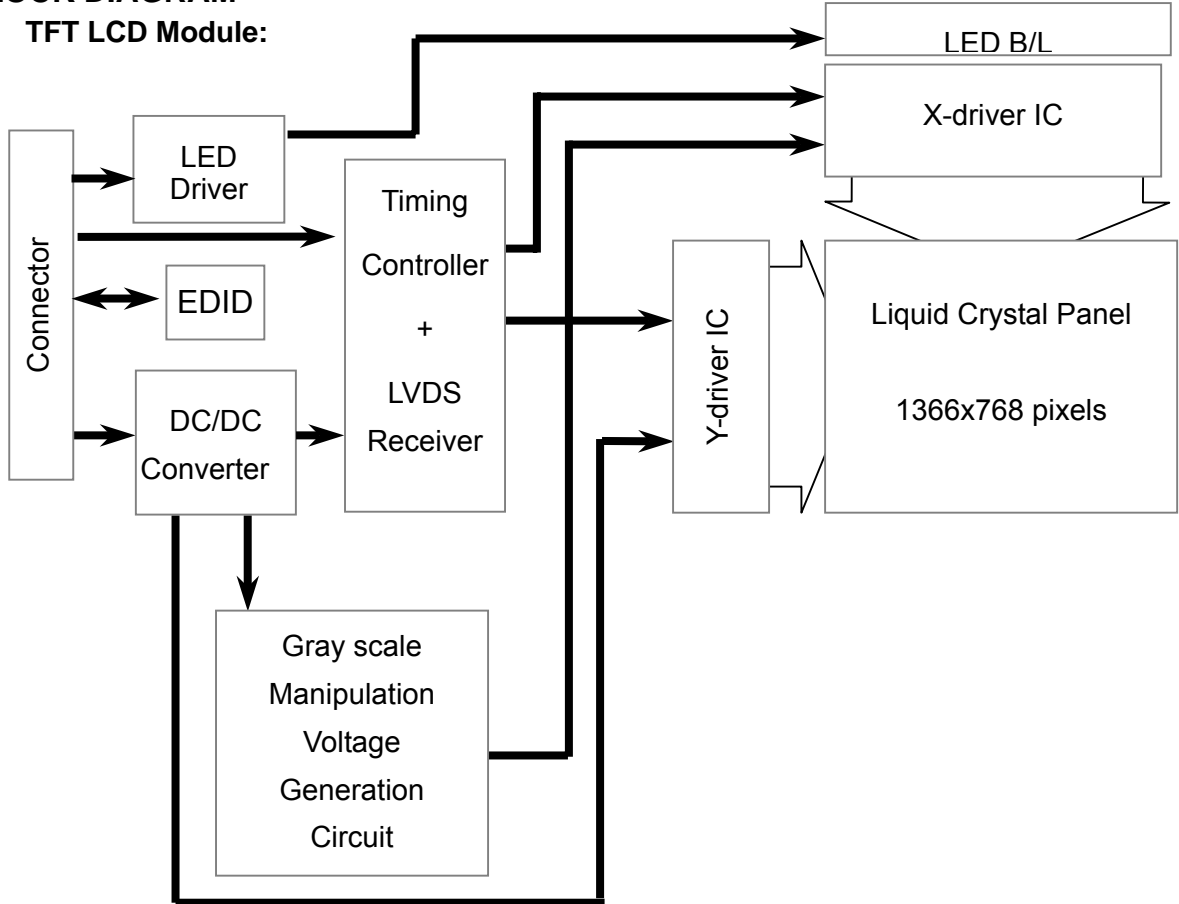

4.2 Pixel Format

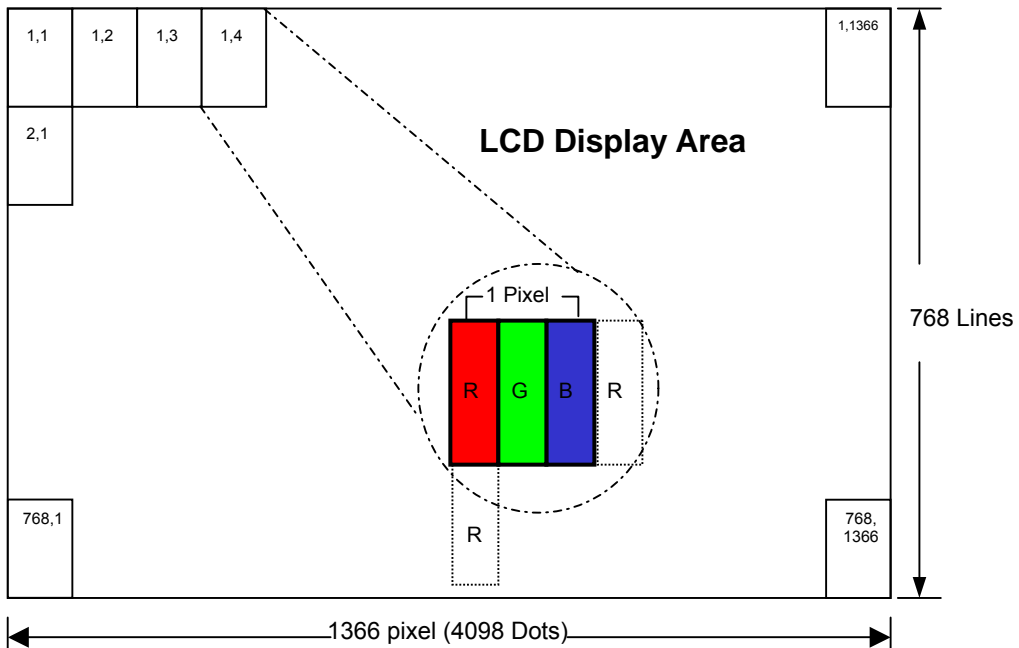



Document Title	HSD121PHW1-A Tentative Specification	Page No.	11/29
Document No.	DC110-000580	Revision	1.0

4.3 Relationship Between Displayed Color and Input

Display	MSB						LSB						MSB						LSB						Gray scale level
	R5	R4	R3	R2	R1	R0	G5	G4	G3	G2	G1	G0	B5	B4	B3	B2	B1	B0							
Basic color	Black	L	L	L	L	L	L	L	L	L	L	L	L	L	L	L	L	L	L	-					
	Blue	L	L	L	L	L	L	L	L	L	L	L	L	H	H	H	H	H	H	-					
	Green	L	L	L	L	L	L	H	H	H	H	H	H	L	L	L	L	L	L	-					
	Light Blue	L	L	L	L	L	L	H	H	H	H	H	H	H	H	H	H	H	H	-					
	Red	H	H	H	H	H	H	L	L	L	L	L	L	L	L	L	L	L	L	-					
	Purple	H	H	H	H	H	H	L	L	L	L	L	L	H	H	H	H	H	H	-					
	Yellow	H	H	H	H	H	H	H	H	H	H	H	H	L	L	L	L	L	L	-					
	White	H	H	H	H	H	H	H	H	H	H	H	H	H	H	H	H	H	H	-					
Gray scale of Red	Black	L	L	L	L	L	L	L	L	L	L	L	L	L	L	L	L	L	L	L0					
	Dark ↑ ↓ Light	L	L	L	L	L	H	L	L	L	L	L	L	L	L	L	L	L	L	L1					
		L	L	L	L	L	L	L	L	L	L	L	L	L	L	L	L	L	L	L2					
		:						:						:						L3...L60					
		H	H	H	H	L	H	L	L	L	L	L	L	L	L	L	L	L	L	L61					
	H	H	H	H	H	L	L	L	L	L	L	L	L	L	L	L	L	L	L62						
	Red	H	H	H	H	H	H	L	L	L	L	L	L	L	L	L	L	L	L	Red L63					
	Gray scale of Green	Black	L	L	L	L	L	L	L	L	L	L	L	L	L	L	L	L	L	L	L0				
Dark ↑ ↓ Light		L	L	L	L	L	L	L	L	L	L	L	H	L	L	L	L	L	L	L1					
		L	L	L	L	L	L	L	L	L	L	L	H	L	L	L	L	L	L	L2					
		:						:						:						L3...L60					
		L	L	L	L	L	L	H	H	H	H	L	H	L	L	L	L	L	L	L61					
L		L	L	L	L	L	H	H	H	H	H	L	L	L	L	L	L	L	L62						
Green		L	L	L	L	L	L	H	H	H	H	H	H	L	L	L	L	L	L	Green L63					
Gray scale of Blue		Black	L	L	L	L	L	L	L	L	L	L	L	L	L	L	L	L	L	L	L0				
	Dark ↑ ↓ Light	L	L	L	L	L	L	L	L	L	L	L	L	L	L	L	L	L	H	L1					
		L	L	L	L	L	L	L	L	L	L	L	L	L	L	L	L	H	L	L2					
		:						:						:						L3...L60					
		L	L	L	L	L	L	L	L	L	L	L	L	H	H	H	H	L	H	L61					
	L	L	L	L	L	L	L	L	L	L	L	L	H	H	H	H	H	L	L62						
	Blue	L	L	L	L	L	L	L	L	L	L	L	L	H	H	H	H	H	H	Blue L63					
	Gray scale of White & Black	Black	L	L	L	L	L	L	L	L	L	L	L	L	L	L	L	L	L	L	L0				
Dark ↑ ↓ Light		L	L	L	L	L	H	L	L	L	L	L	H	L	L	L	L	L	H	L1					
		L	L	L	L	L	H	L	L	L	L	L	H	L	L	L	L	H	L	L2					
		:						:						:						L3...L60					
		H	H	H	H	L	H	H	H	H	H	L	H	H	H	H	H	L	H	L61					
H		H	H	H	H	L	H	H	H	H	H	L	H	H	H	H	H	L	L62						
White		H	H	H	H	H	H	H	H	H	H	H	H	H	H	H	H	H	H	White L63					



Document Title	HSD121PHW1-A Tentative Specification	Page No.	12/29
Document No.	DC110-000580	Revision	1.0

5.0 INTERFACE PIN CONNECTION

5.1 TFT LCD Module : CN1 (Input signal): : IPEX 20455-040E-12 (IPEX or equivalent)

Pin No.	Signal	Description
1	NC	Not connection
2	AVDD	Power Supply, 3.3V (typical)
3	AVDD	Power Supply, 3.3V (typical)
4	DVDD	DDC 3.3V power
5	NC	No Connection
6	SCL	EDID Clock
7	SDA	EDID Data
8	Rin0-	- LVDS differential data input (R0-R5,G0)
9	Rin0+	+LVDS differential data input (R0-R5,G0)
10	GND	Ground
11	Rin1-	- LVDS differential data input(G1-G5,B0-B1)
12	Rin1+	+LVDS differential data input (G1-G5,B0-B1)
13	GND	Ground
14	Rin2-	- LVDS differential data input (B2-B5,HS,VS,DE)
15	Rin2+	+LVDS differential data input (B2-B5,HS,VS,DE)
16	GND	Ground
17	CIKIN-	-LVDS differential clock input
18	CIKIN+	+LVDS differential clock input
19	GND	Ground
20	NC	No Connection
21	NC	No Connection
22	GND	Ground-Shield
23	NC	No Connection
24	NC	No Connection
25	GND	Ground-Shield
26	NC	No Connection
27	NC	No Connection
28	GND	Ground-Shield
29	NC	No Connection
30	NC	No Connection
31	VLED_GND	LED Ground
32	VLED_GND	LED Ground
33	VLED_GND	LED Ground
34	NC	No Connection
35	PWM	PWM Signal for LED dimming control
36	LED_EN	LED Enable Pin (+3V Input)
37	NC	No Connection
38	VLED	LED Power Supply 7-21V
39	VLED	LED Power Supply 7-21V
40	VLED	LED Power Supply 7-21V

Note : The brightness of LCD panel could be changed by adjusting PWM



Document Title	HSD121PHW1-A Tentative Specification	Page No.	13/29
Document No.	DC110-000580	Revision	1.0

6.0 ELECTRICAL CHARACTERISTICS

6.1 TFT LCD Module

Item	Symbol	Min.	Typ.	Max.	Unit	Note
Supply Voltage	V_{DD}	3.0	3.3	3.6	V	Note (2)
Current of power supply	I_{DD}	-	0.3	-	A	$V_{DD} = 3.3V$, L0 pattern
Inrush current	I_{RUSH}	-	-	1.50	A	Note (2)

Note (1): V_{DD} -dip condition:

When V_{DD} operating within 2.7V $V_{DD} < 3.0V$, t_d 10ms, the display may momentarily become abnormal.

$V_{DD} < 2.7V$, V_{DD} dip condition should also follow the Power On/Off conditions for supply voltage.

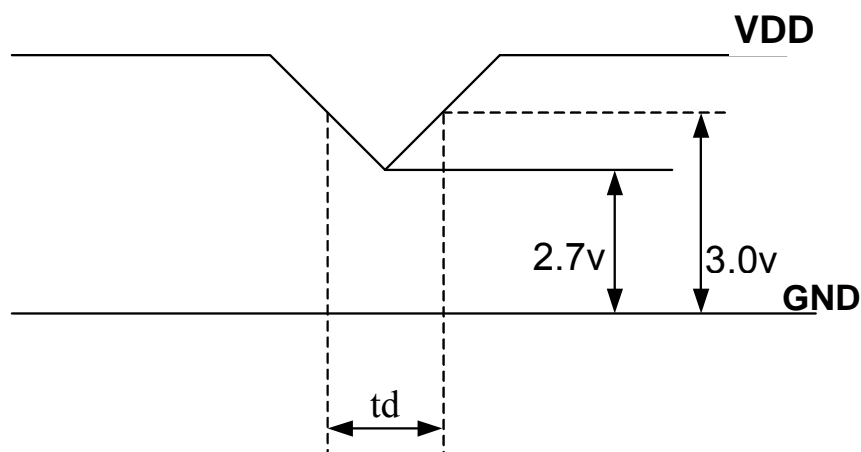



Document Title	HSD121PHW1-A Tentative Specification	Page No.	14/29
Document No.	DC110-000580	Revision	1.0

Note : (2) Power on Inrush current test circuit

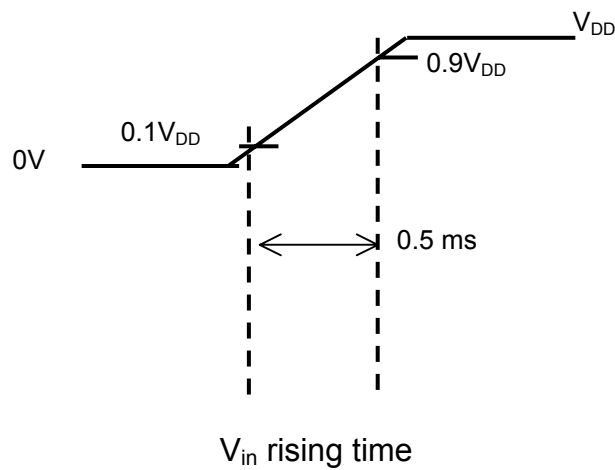
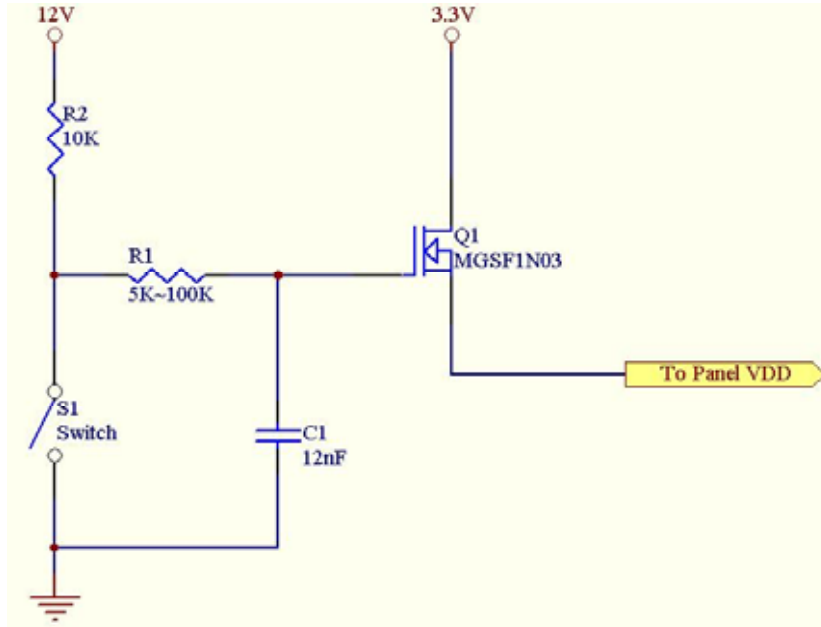



Document Title	HSD121PHW1-A Tentative Specification	Page No.	15/29
Document No.	DC110-000580	Revision	1.0

6.2 Switching Characteristics for LVDS Receiver

Item	Symbol	Min.	Typ.	Max.	Unit	Conditions
Differential Input High Threshold	V _{th}	-	-	100	mV	V _{CM} =1.2V
Differential Input Low Threshold	V _{tl}	-100	-	-	mV	
Input Current	I _{IN}	-10	-	+10	uA	
Differential input Voltage	V _{ID}	0.1	-	0.6	V	
Common Mode Voltage Offset	V _{CM}	(V _{ID} /2)	1.25	1.8-0.4-(V _{ID} /2)	V	

6.3 Bit Mapping & Interface Definition

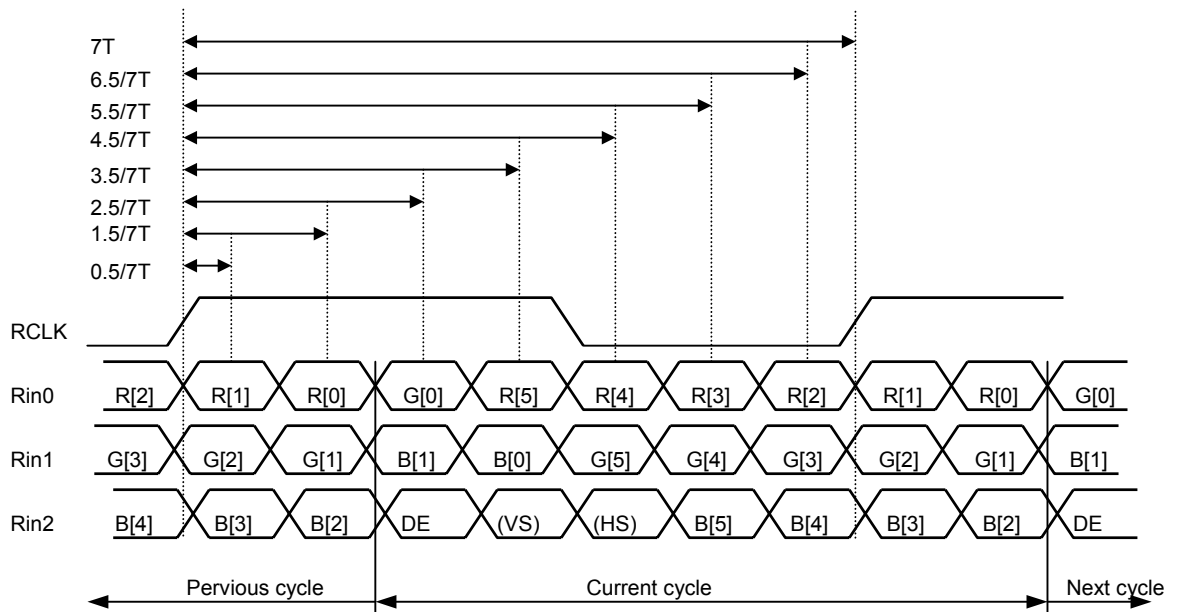

LVDS Receiver Input Timing Definition
for 6bits LVDS input



Document Title	HSD121PHW1-A Tentative Specification	Page No.	16/29
Document No.	DC110-000580	Revision	1.0

6.4 Interface Timing (DE mode)

Item	Symbol	Min.	Typ.	Max.	Unit
Frame Rate	--	(55)	(60)	(TBD)	Hz
Frame Period	t1	(778)	(806)	(888)	line
Vertical Display Time	t2	(768)	(768)	(768)	line
Vertical Blanking Time	t3	(10)	(38)	(120)	line
1 Line Scanning Time	t4	(1437)	(1560)	(1936)	clock
Horizontal Display Time	t5	(1366)	(1366)	(1366)	clock
Horizontal Blanking Time	t6	(71)	(194)	(570)	clock
Clock Rate	t7	(50.3)	(75.44)	(80)	MHz

Timing Diagram of Interface Signal (DE mode)

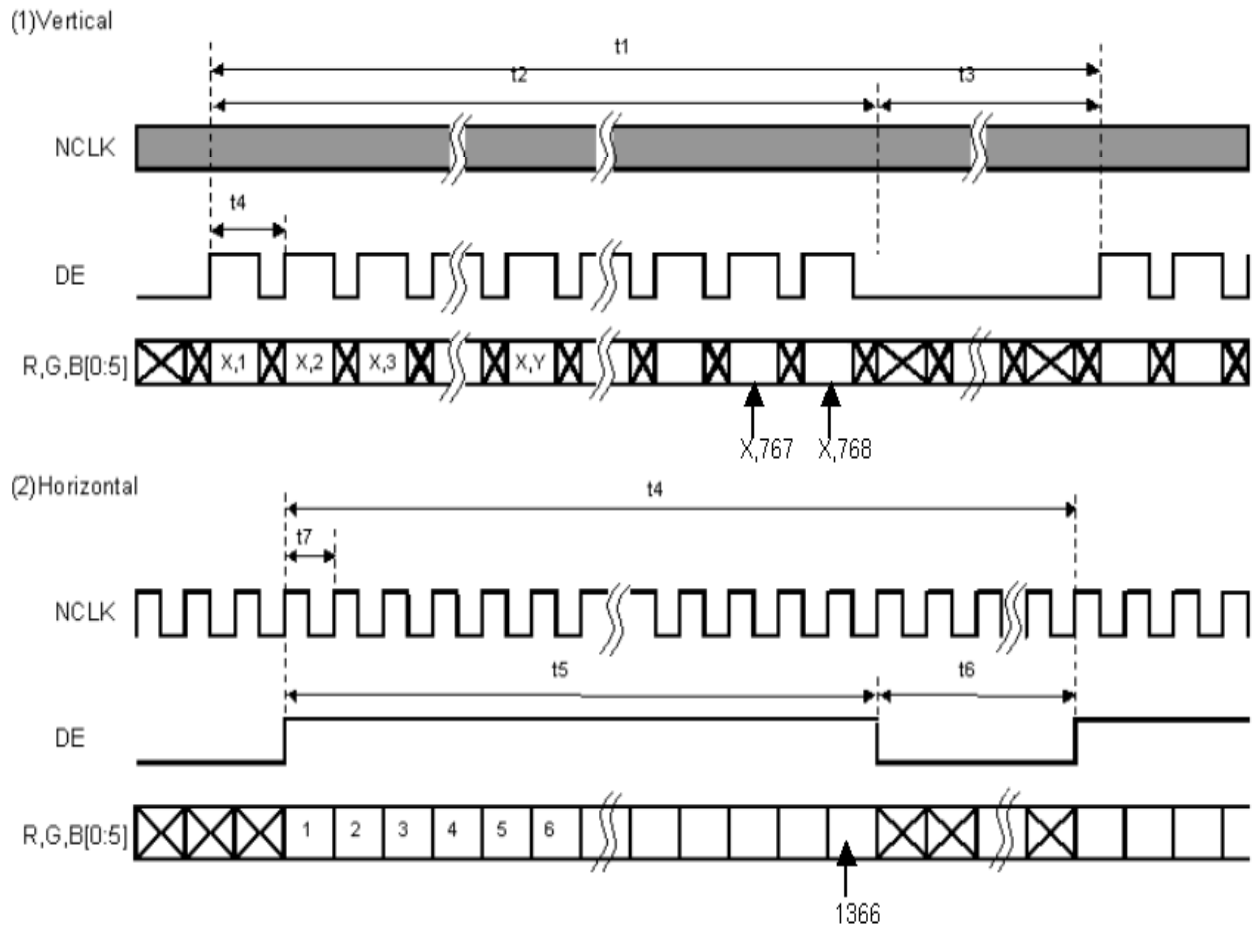

Document Title	HSD121PHW1-A Tentative Specification	Page No.	17/29
Document No.	DC110-000580	Revision	1.0

6.5 Power On / Off Sequence

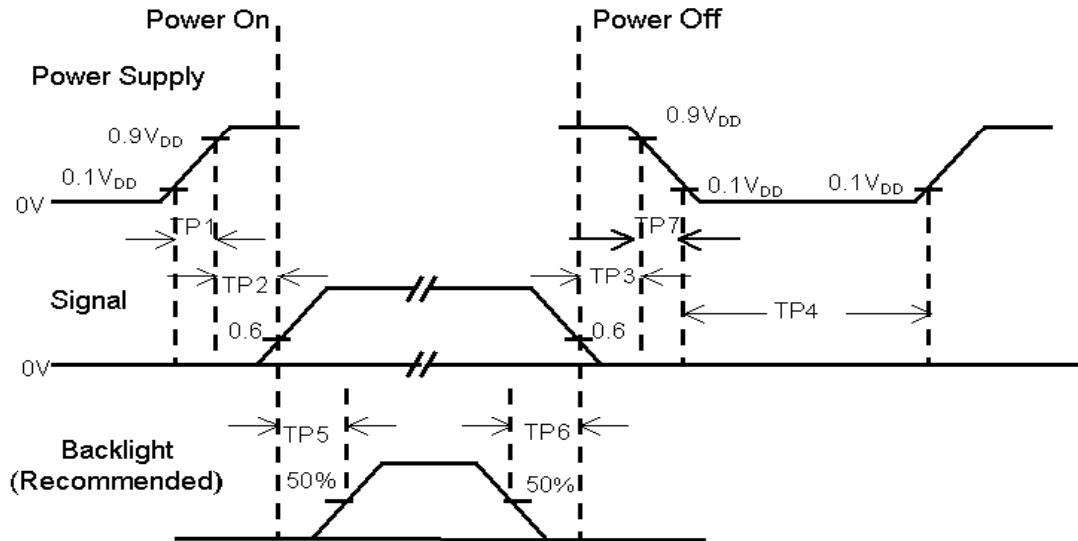

Item	Min.	Typ.	Max.	Unit	Remark
TP1	0.5	--	10	msec	
TP2	0	--	50	msec	
TP3	0	--	50	msec	
TP4	1000	--	--	msec	
TP5	200	--	--	msec	
TP6	200	--	--	msec	
TP7	0.5	--	10	msec	

- Note :**
- (1) The supply voltage of the external system for the module input should be the same as the definition of V_{DD} .
 - (2) Apply the lamp voltage within the LCD operation range. When the back-light turns on before the LCD operation or the LCD turns off before the back-light turns off, the display may momentarily become white.
 - (3) In case of V_{DD} = off level, please keep the level of input signal on the low or keep a high impedance.
 - (4) TP4 should be measured after the module has been fully discharged between power off and on period.
 - (5) Interface signal shall not be kept at high impedance when the power is on.



Document Title	HSD121PHW1-A Tentative Specification	Page No.	18/29
Document No.	DC110-000580	Revision	1.0

6.6 Backlight Unit

Parameter	Symbol	Min	Typ	Max	Units	Condition
LED Current	I_F	--	(20)	(20.6)	mA	Ta=25
LED Voltage	V_F	(3.0)	(3.2)	(3.4)	Volt	Ta=25
LED Power consumption	P_{LED}	--	(1.92)	(2.1)	Watt	Ta=25 Note (1)
LED Life-Time	N/A	10,000	--	--	Hour	Ta=25 $I_F=20mA$ Note (2)

Note (1): Calculator value for reference $P=I_F \times V_F \times N$ (LED Qty')

Note (2): The LED lifetime defines as the estimated time to 50% degradation of final luminous.

6.7 LED Driver

6.7.1 Absolute Maximum Ratings

Item	Symbol	Min.	Max.	Unit	Note
LED Power Supply voltage	V_{LED}	-0.3	24	Volt	
LED_EN, PWM pin Voltage	V_{EN}, V_{PWM}	--	5.5	Volt	

6.7.2 DC Electrical Characteristics

Parameter	Symbol	Min	Typ	Max	Units	Remark
LED Power Supply Voltage	V_{LED}	7.0	--	21.0	Volt	
LED_EN High Threshold	V_{ENH}	2.0	--	--	Volt	
LED_EN Low Threshold	V_{ENL}	--	--	0.3	Volt	
PWM High Threshold	V_{PWMH}	2.0	--	--	Volt	
PWM Low Threshold	V_{PWML}	--	--	0.15	Volt	
PWM Frequency	F_{PWM}	(225)	--	(275)	Hz	
PWM Duty Cycle	T_D	(10)	--	(100)	%	Note(1)



Document Title	HSD121PHW1-A Tentative Specification	Page No.	19/29
Document No.	DC110-000580	Revision	1.0

Note (1): PWM Duty Cycle

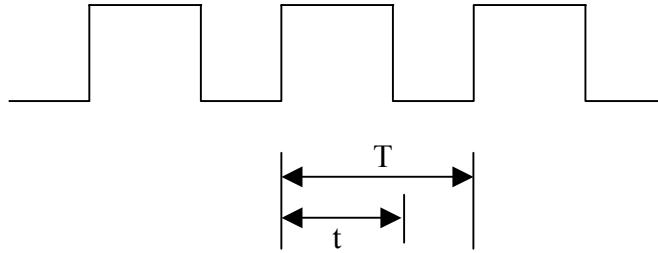

$$\text{Duty Cycle} = (t / T) * 100\%$$

6.7.3 LED Power on/off sequence

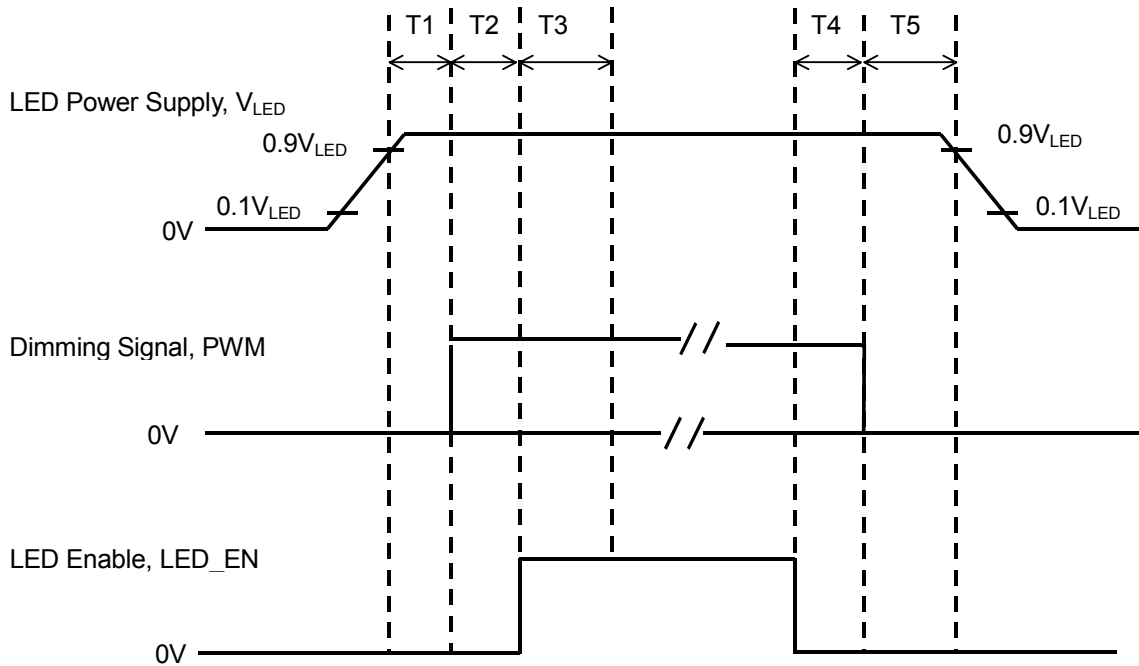



HannStar Display Corp.

Document Title	HSD121PHW1-A Tentative Specification	Page No.	20/29
Document No.	DC110-000580	Revision	1.0

Symbol	Value			Unit
	Min	Typ	Max	
T1	10	--	--	ms
T2	10	--	--	
T3	50	--	--	
T4	0	--	--	
T5	10	--	--	

Note (1): The duty of LED dimming signal should be more than 20% in T2 and T3

Note (2): PWM can adjust brightness to control Pin. Pulse duty the bigger the brighter



Document Title	HSD121PHW1-A Tentative Specification	Page No.	21/29
Document No.	DC110-000580	Revision	1.0

7.0 Reliability test items

No.	Item	Conditions	Remark
1	High Temperature Storage	Ta=+60°C, 240hrs	
2	Low Temperature Storage	Ta=-20°C, 240hrs	
3	High Temperature Operation	Ta=+50°C, 500hrs	
4	Low Temperature Operation	Ta=0°C, 500hrs	
5	Thermal Cycling Test (non operation)	-20°C(30min)→+60°C(30min),100 cycles	
6	Vibration	Sine Wave 1.5G, 5~500Hz, XYZ 30min/each direction	
7	Shock	Half-Sine, 200G, 2ms, ±XYZ, 1time	

Storage / Operating temperature

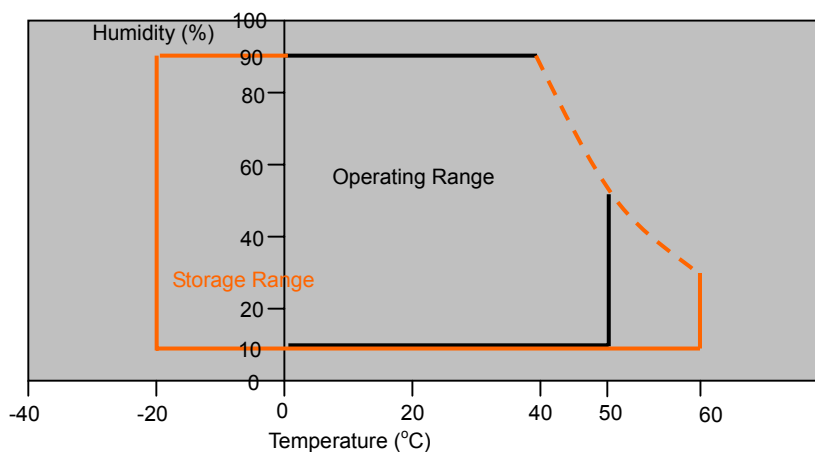

Note .Max wet bulb temp.=39°C



HannStar Display Corp.

Document Title	HSD121PHW1-A Tentative Specification	Page No.	22/29
Document No.	DC110-000580	Revision	1.0

8.0 OUTLINE DIMENSION

8.1 Front View Outline Dimension

Unit : mm

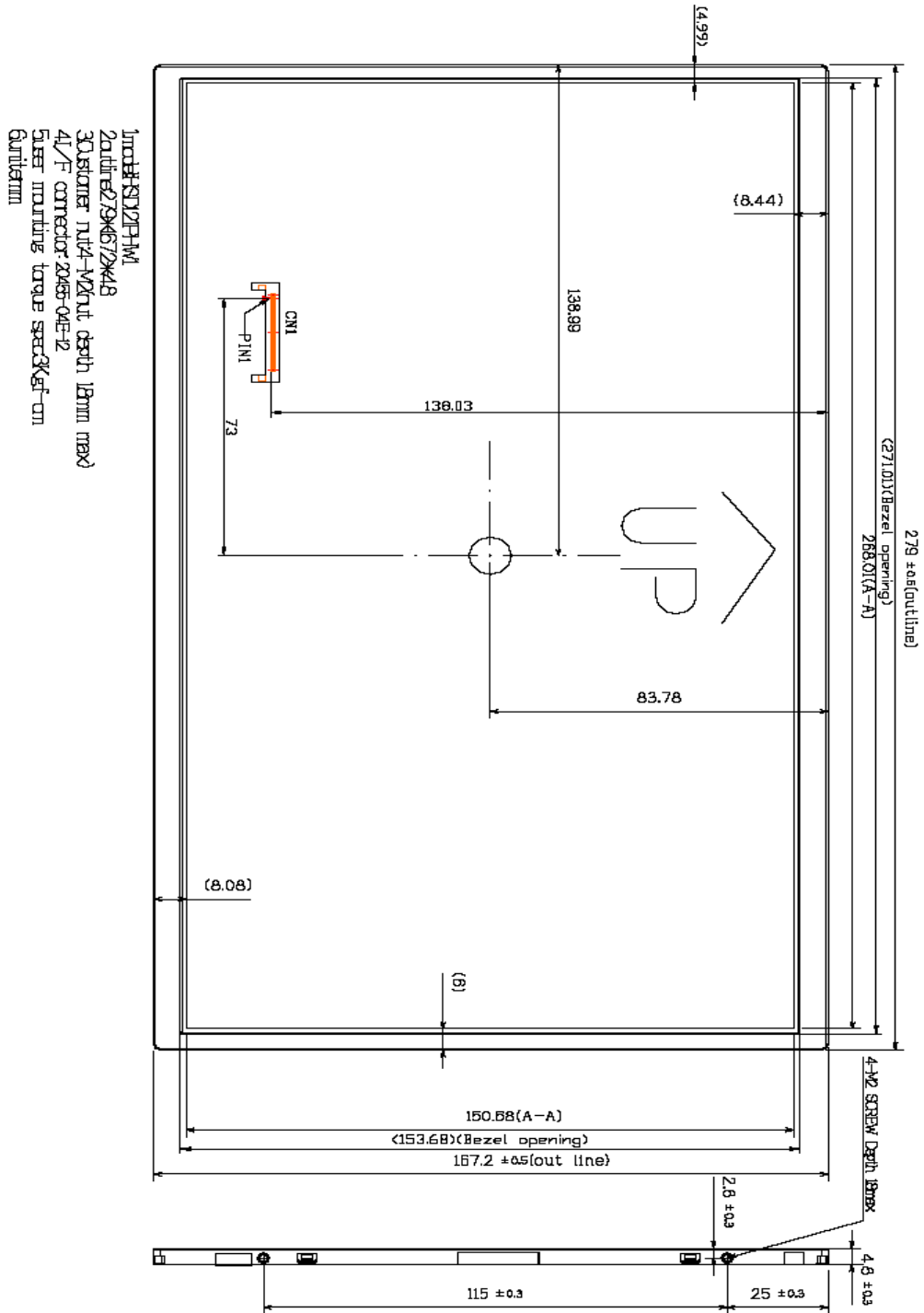



Document Title	HSD121PHW1-A Tentative Specification	Page No.	23/29
Document No.	DC110-000580	Revision	1.0

8.2 Back View Outline Dimension

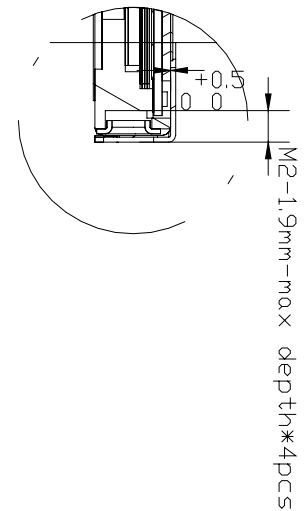
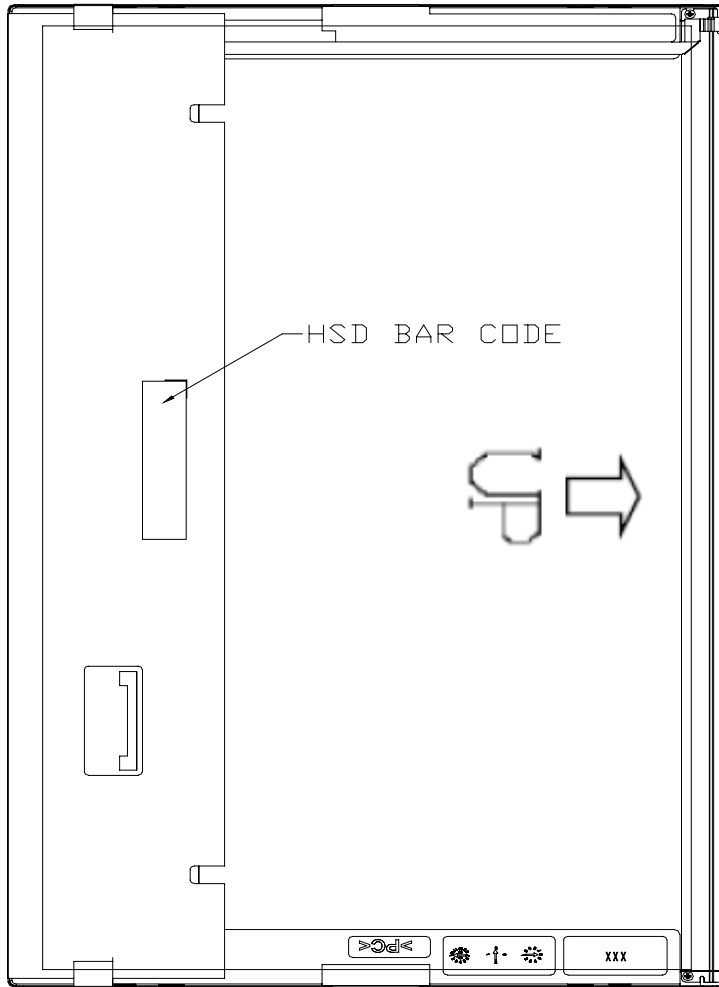



HannStar Display Corp.

Document Title	HSD121PHW1-A Tentative Specification	Page No.	24/29
Document No.	DC110-000580	Revision	1.0

9.0 LOT MARK

9.1 Lot Mark

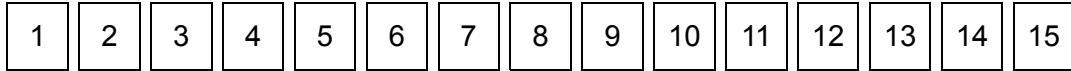

Code 1,2,3,4,5,6: HannStar internal flow control code.

Code 7: production location.

Code 8: production year.

Code 9: production month.

Code 10,11,12,13,14,15: serial number.

Note (1) Production Year

Year	2001	2002	2003	2004	2005	2006	2007	2008	2009	2010
Mark	1	2	3	4	5	6	7	8	9	0

Note (2) Production Month

Month	Jan.	Feb.	Mar.	Apr.	May.	Jun.	Jul.	Aug.	Sep.	Oct.	Nov.	Dec.
Mark	1	2	3	4	5	6	7	8	9	A	B	C

9.2 Location of Lot Mark

- (1) The label is attached to the backside of the LCD module.
- (2) This is subject to change without prior notice.

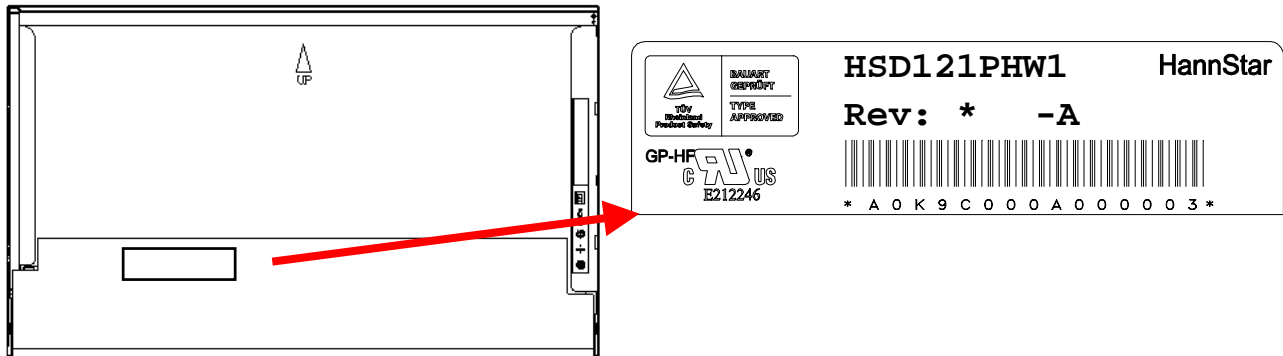



Document Title	HSD121PHW1-A Tentative Specification	Page No.	25/29
Document No.	DC110-000580	Revision	1.0

10.0 PACKAGE SPECIFICATION

10.1 Packing form

- (1) Package quantity in one carton: TBD.
- (2) Carton size: TBD.

10.2 Packing assembly drawings

11.0 GENERAL PRECAUTION

11.1 Use Restriction

This product is not authorized for use in life supporting systems, aircraft navigation control systems, military systems and any other application where performance failure could be life-threatening or otherwise catastrophic.

11.2 Disassembling or Modification

Do not disassemble or modify the module. It may damage sensitive parts inside LCD module, and may cause scratches or dust on the display. HannStar does not warrant the module, if customers disassemble or modify the module.

11.3 Breakage of LCD Panel

- 11.3.1. If LCD panel is broken and liquid crystal spills out, do not ingest or inhale liquid crystal, and do not contact liquid crystal with skin.
- 11.3.2. If liquid crystal contacts mouth or eyes, rinse out with water immediately.
- 11.3.3. If liquid crystal contacts skin or cloths, wash it off immediately with alcohol and rinse thoroughly with water.
- 11.3.4. Handle carefully with chips of glass that may cause injury, when the glass is broken.

11.4 Electric Shock

- 11.4.1. Disconnect power supply before handling LCD module.
- 11.4.2. Do not pull or fold the LED cable.
- 11.4.3. Do not touch the parts inside LCD modules and the fluorescent LED's connector or cables in order to prevent electric shock.



Document Title	HSD121PHW1-A Tentative Specification	Page No.	26/29
Document No.	DC110-000580	Revision	1.0

11.5 Absolute Maximum Ratings and Power Protection Circuit

- 11.5.1. Do not exceed the absolute maximum rating values, such as the supply voltage variation, input voltage variation, variation in parts' parameters, environmental temperature, etc., otherwise LCD module may be damaged.
- 11.5.2. Please do not leave LCD module in the environment of high humidity and high temperature for a long time.
- 11.5.3. It's recommended to employ protection circuit for power supply.

11.6 Operation

- 11.6.1 Do not touch, push or rub the polarizer with anything harder than HB pencil lead.
- 11.6.2 Use fingerstalls of soft gloves in order to keep clean display quality, when persons handle the LCD module for incoming inspection or assembly.
- 11.6.3 When the surface is dusty, please wipe gently with absorbent cotton or other soft material.
- 11.6.4 Wipe off saliva or water drops as soon as possible. If saliva or water drops contact with polarizer for a long time, they may causes deformation or color fading.
- 11.6.5 When cleaning the adhesives, please use absorbent cotton wetted with a little petroleum benzine or other adequate solvent.

11.7 Mechanism

Please mount LCD module by using mounting holes arranged in four corners tightly.

11.8 Static Electricity

- 11.8.1 Protection film must remove very slowly from the surface of LCD module to prevent from electrostatic occurrence.
- 11.8.2 Because LCD module use CMOS-IC on circuit board and TFT-LCD panel, it is very weak to electrostatic discharge. Please be careful with electrostatic discharge. Persons who handle the module should be grounded through adequate methods.

11.9 Strong Light Exposure

The module shall not be exposed under strong light such as direct sunlight. Otherwise, display characteristics may be changed.

11.10 Disposal

When disposing LCD module, obey the local environmental regulations.



Document Title	HSD121PHW1-A Tentative Specification	Page No.	27/29
Document No.	DC110-000580	Revision	1.0

HSD121PHW1- A01

(For this model, Interface connection, Outline dimension, Lot mark are added.)

12.1 Interface Connection

TFT LCD Module : CN1 (Input signal): FI-XB30SL-HF10 (JAE or equivalent)

Pin No.	Signal	Description
1	GND	Ground
2	VDD	3.3V Power
3	VDD	3.3V Power
4	V_EDID	3.3V Power for EDID
5	PWM	System PWM Signal Input
6	CLK_EDID	EDID Clock Input
7	DATA_EDID	EDID Data Input
8	RXIN0-	LVDS Signal - channel0-
9	RXIN0+	LVDS Signal+ channel0+
10	GND	Ground
11	RXIN1-	Data Input channel1-
12	RXIN1+	Data Input channel1+
13	GND	Ground
14	RXIN2-	Data Input channel2-
15	RXIN2+	Data Input channel2+
16	GND	Ground
17	RXCLKIN-	Data Input CLK-
18	RXCLKIN+	Data Input CLK+
19	GND	Ground
20	NC	NC
21	NC	NC
22	GND	Ground
23	GND	Ground
24	VLED	LED Input voltage 7V~21V
25	VLED	LED Input voltage 7V~21V
26	VLED	LED Input voltage 7V~21V
27	LED_EN	LED Enable Signal
28	NC	NC
29	NC	NC
30	NC	NC

Note : The brightness of LCD panel could be changed by adjusting PWM



Document Title	HSD121PHW1-A Tentative Specification	Page No.	29/29
Document No.	DC110-000580	Revision	1.0

12.3 Back View Outline Dimension

